

NORTH WESTERN RAILWAY

MINUTES OF IRTTC MEETING HELD AT CHENNAI

FROM 27.01.16 TO 29.01.16

EXTENSION OF TRAIN NO. 15273/74 Rakaxul-Delhi exp up to SGNR via UMB,BTI,FKA
Merging 14731/32 DLI-FKA EXP

Abstract timings

15273		Station	15274	
ARR	DEP		ARR	DEP
09.20	09.05	RXL	16.45	
09.20	9.50	DLI	16.00	17.15
20.30	21.35	FKA	2.30	2.40
22.05		SGNR		0.30
	1582	Distance	1582	
	37.00	TOR	36.00	
	42.80	Avg speed	44.00	

Frequency - Daily

Stoppages proposed on extended portion :: - As of 14731/32 & ABS
Composition: - ACCN 2 GSCN 5 GS 12 SLR 2 =21

Additional rake reqd Nil (Only ACCN2,GSCN 5,GS 1.)

Primary Maintenance: RXL with RBPC As Exists

Loco required: - Nil

1 Existing rake link no. 1 14711/12 SGNR-HW,12481/82 SGNR-DLI &14731/32 DLI-FKA

SGNR RSKH BTI DLI FKA

05.45	>	12482	12481
02.30	<	15.00	
04.10	>	14.30	
14712		14711	
14.15	<	1.05	
12.45	>	02.00	
13.20		DLI-FKA 14731	
		FKA-DLI 14732	

NEW TRAINSuvidha Exp BKN-DDR/BDS Via BLDI

Abstract timings,

Tentative timing

Station		Arr.	Dep.
BKN-DDR/BDS	DDR/BDS-BKN		
18.00	18.15	JU	7.45
0.10	0.30	BLDI	2.35
12.00FRI		DDR/BDS	-
		Distance	1240
		TOR	22.35
		Avg speed	55.1

Frequency - Weekly

Stoppages proposed: on NWR.... NOK,NGO,MTD,JU,LUNI,SMR,MKSR,JOR

,MON,MBNL,RNV,DQN,

Number of rake required:.....ONE

Number of loco required:.....ONE

Composition:- ACCW-1,ACCN-2 GSCN-10 GS-6,SLR-1,SLRD-1 = 21
 Primary Maintenance: BKN with RBPC

Rake Link

BKN

DDR/ BDS

BKN-DDR/BDS

DDR/BDS-BKN

14.35(5)

13.40(4) -----> Repeat ----->

Operationally not feasible
 as 2 coaches are not available.

CPTM/WBR
 29/1/16
 SMC

CPTM-NWR
 28.1.16

29/1/16
 Rly Board

SUVIDHA EXPRESS
Operationally Not
feasible.

NORTH WESTERN RAILWAY
MINUTES OF IRTTC MEETING HELD AT CHENNAI
FROM 27.01.16 TO 29.01.16

EXTENSION OF TRAIN NO. 14705/06 DEE-BGKT up to GIMB by merging 22483/84 JU-GIM T/W EXP
 (RB No. 22.)

Abstract timings

Proposed Station	Proposed 14705 DEE-BGKT-GIM		DEE	BGKT	BLDI	GIMB	TOR	Distance	Avg speed
	Arr.	Dep.							
Proposed	19.15	7.05	19.15	19.17	1.55	1.45	23.15	1182	50.80
	14706 GIM-BGKT-DEE	22.10	22.10	9.48	3.25	3.35	-	1182	50.80

Stoppages proposed on extended portion As exist

Number of rake required: NIL

Primary Maintenance: BKN with RBPC

Loco requirement: One

Proposed Rake Link

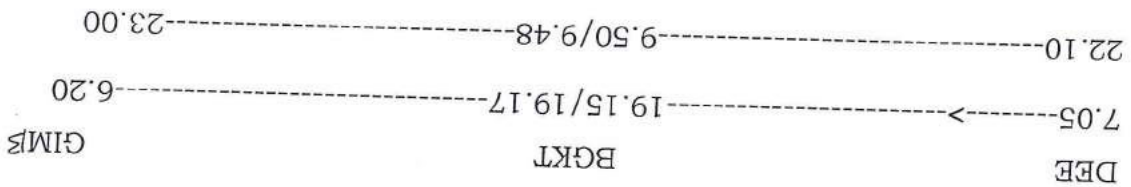

Remarks:

CPTM/WVR
 29/1/16
 5m/c

CPTM NWR
 28.1.16
 3/

29/1/16
 /RB

SOUTHERN RAILWAY

Minutes of the IRTTC Meeting held at Chennai from 27.1.2016 to 29.1.2016

INTRODUCTION OF EXPRESS TRAINS

Chennai Central/Chennai Egmore – Coimbatore (Tri- Weekly) Express

Tentative timings:

MAS/MS-CBE Exp.	↑	Station	↓	CBE-MAS/MS Exp.
(Mon, Wed, Sat) 10.00	(d)	MAS	(a)	16.55 (Tue, Thu, Sun)
10.35/10.45	(a/d)	MS	(a/d)	16.10/16.20
13.40/13.45	(a/d)	VM	(a/d)	13.00/13.20
14.30/14.50	(a/d)	VRI	(a/d)	11.50/12.10
17.25/17.50	(a/d)	SA	(a/d)	08.15/08.40
18.45/18.50	(a/d)	ED	(a/d)	07.15/07.20
(Mon, Wed, Sat) 21.00	(a)	CBE	(d)	05.30 (Tue, Thu, Sun)

Rly.	No. of stops	15/16	SR
		MSB, (Up direction only), TBM, CGL, MLMR, TMV, VM, VRI, CHSM, ATU, SXT, SA, SGE, ED, TUP, CBF (Down direction)	

1.	Frequency	Tri-Weekly
2.	Maintenance	PM : Chennai Central (with RBPC)
3.	Other end attention	Coimbatore
4.	Distance	521 kms.
5.	Running time	11 hrs. (MAS-CBE) and 11 hrs. 25 mts. (CBE-MAS)
6.	Speed	46.36 kmph (MAS-CBE) and 45.62 kmph (CBE-MAS)
7.	Route	MSB, MS, VM, VRI, SA
8.	Composition	CZAC - 1, GSCZ - 6, GS - 6, SLR - 2 = 15 coaches
9.	No of rakes required.	One rake
10.	Loco	MAS - VRI: AC VRI - SA: DSL SA - CBE: AC
11.	Remarks	Repeated requests from Hon'ble MPs Shri V. Panneerselvam, Dr. K. Kamaraj & Shir Nagarajan

Rake Link :

MAS	MAS-CBE	CBE	MAS
(Mon, Wed, Sat) 10.00	21.00 (Tue, Thu, Sun)	05.30 (Tue, Thu, Sun)	(Mon, Wed, Sat) 16.55
repeat	CBE-MAS	repeat	
	1032		

Agreed to.

28/1/16
Railway Board

CPTM/SR

[Signature]

SOUTHERN RAILWAY

Minutes of the IRTTC Meeting held at Chennai from 27.1.2016 to 29.1.2016

INTRODUCTION OF EXPRESS TRAINS

Chennai Central – Madurai Air-Conditioned Superfast (Weekly) Express

Tentative timings:

MAS-MDU AC Exp.	↑	Station	↓	MAS-MAS AC Exp.
(Fri) 22.30	(d)	MAS	(a)	07.10 (Mon)
(Sat) 07.10	(a)	MDU	(d)	22.45 (Sun)

Rly.	No. of stoppage details	
SR	1	Salem in both directions (Operational halt for traction & crew change)

1.	Frequency	Weekly
2.	Maintenance	PM : Chennai Central (with RBPC)
3.	Other end attention	Madurai
4.	Distance	560 kms.
5.	Running time	8 hrs. 40 mts. (MAS-MDU) & 8 hrs. 25 mts. (MDU-MAS)
6.	Speed	64.59 kmph (MAS-MDU) & 66.51 kmph (MDU-MAS)
7.	Route	JTJ, SA, NMKL, KRR, DG
8.	Composition	WLRM-2, WFAC-1, WACGW-3, WACCN-9 = 15coaches
9.	No of rakes required	Nil (utilising lie-over rake of T.No.22205/22206 MAS-MDU Bi-weekly AC Duronto Exp.)
10.	Loco	ONE D5L
11.	Nominated enroute Watering station	Salem, AOS, KPD, KRR, DA, NMKL,

Rake Link :

MAS	22205	07.10 (Tue)
MDU	22206	22.45 (Tue)
MAS	22205	07.10 (Thu)
MDU	22206	22.45 (Thu)
MAS	22205	07.10 (Sat)
MDU	22206	22.45 (Sat)
MAS	22205	07.10 (Sun)
MDU	22206	22.45 (Sun)

3096
516
516
516
516
516
516
516
516
516

No. of rakes : One (SR) PM : MAS

Agreed to.

28/1/16
/Railway Board

CPTM/SR

[Signature]

SOUTHERN RAILWAY

Minutes of the IRTTC Meeting held at Chennai from 27.1.2016 to 29.1.2016

INTRODUCTION OF EXPRESS TRAINS

SALEM – KARUR PASSENGER (via Namakkal)
(now running as Passenger Special train)

Tentative timings:

SA-KRR Passr.	↑	Station	↓	KRR-SA Passr.
11.30	(d)	SA	(a)	16.40
13.30	(a)	KRR	(d)	14.40

1.	Frequency	→ Daily
2.	Maintenance	PM : Salem (with RBPC)
3.	Other end attention	Karur
4.	Distance	85 kms.
5.	Running time	2 hrs. (SA-KRR-SA)
6.	Speed	42.5 kmph (SA-KRR-SA)
7.	Composition	6 GS, 2 SLR = 8 coaches
8.	No of rakes required	Nil

Agreed to.

S. S. S. S.
/ Railway Board

CPTM/SR

H. S. S.

SOUTHERN RAILWAY

Minutes of the IRTTC Meeting held at Chennai from 27.1.2016 to 29.1.2016

EXTENSION OF TRAINS

Train No.17651/17652 Chennai Egmore-Kacheguda (Daily) Exp. and Train No.17643/17644 Chennai Egmore-Kakinada Port (Daily) Exp. to Chengalpattu.

T.No.17652	COA-MS-CGL	↑	Station	↓	T.No.17643	CGL-MS-COA	T.No.17651
16.30	-	d	KCG	a	-	-	07.55
-	14.40	a/d	COA	a/d	09.40	-	-
07.15/07.25	06.35/06.45	a/d	MS	a/d	17.10/17.20	16.50/17.00	16.00
09.05	07.45	a	CGL	d	15.20	16.00	

1. Frequency	Daily
2. Maintenance	PM : Kacheguda (with RBPC)
3. Other end attention	Chengalpattu & Kakinada Port
4. Distance over extended run	55 kms. between MS-CGL
5. Stoppages over extended portion	MBM (Down direction) and TBM
6. Running time	16 hrs. 35 mts. (KCG-CGL) & 15 hrs. 55 mts. (CGL-KCG)
7. Speed	49.39 kmph (KCG-CGL) & 52.01 kmph (CGL-KCG)
8. Composition	SLR-2, ACCW-1, ACCN-2, GSCN-8, GS-3 = 16 coaches
9. No of rakes required	Nil (extension during lie-over period)

Rake Link :

16.30	KCG	17652	09.05	CGL	17643	09.40	COA
15.20							
07.55							
16.00							
repeat							

No. of rakes : Four (SCR) PM : KCG OEA: COA/CGL

Agreed to.

Railway Board

CPTM/SCR

CPTM/SR

SOUTHERN RAILWAY

Minutes of the IRTTC Meeting held at Chennai from 27.1.2016 to 29.1.2016

EXTENSION OF TRAINS

Train No. 15930/15929 Dibrugarh-Chennai Egmore Weekly Express upto Tiruchchirappalli

Day	T.No.15930	↑	Stations	↓	T.No.15929	Day
Sun	23.45	(d)	DBRG	(a)	18.00	Sun
Wed	20.00/20.15	(a/d)	MS	(a/d)	22.15/22.30	Thu
Thu	04.15	a	TPJ	d	16.00	Thu

Frequency	Weekly	Distance over extended run to TPJ	336 kms. over extended run to TPJ	Total distance : 3346+336=3682 kms.	Maintenance	PM : DBRG SM : TPJ	Stoppages over extended portion	MBM (Up direction), TBM, CGL, VRI, SRGM	Running Time	76 hrs. 30 mts. (DBRG-TPJ) & 74 hrs. (TPJ-DBRG)	Speed	48.13 kmph (DBRG-TPJ) & 49.76 kmph (TPJ-DBRG)	Composition	SLR-2, ACCW-1, ACCN-4, GSCN-13, GS-2 = 22 coaches	No of rakes required.	NIL (extension during lie-over period)	
1.	Frequency	Weekly	Distance over extended run to TPJ	336 kms. over extended run to TPJ	Total distance : 3346+336=3682 kms.	Maintenance	PM : DBRG SM : TPJ	Stoppages over extended portion	MBM (Up direction), TBM, CGL, VRI, SRGM	Running Time	76 hrs. 30 mts. (DBRG-TPJ) & 74 hrs. (TPJ-DBRG)	Speed	48.13 kmph (DBRG-TPJ) & 49.76 kmph (TPJ-DBRG)	Composition	SLR-2, ACCW-1, ACCN-4, GSCN-13, GS-2 = 22 coaches	No of rakes required.	NIL (extension during lie-over period)

Rake link :

DBRG	TPJ	repeat	No. of rakes : One (NFR)
(Sun) 23.45	04.15 (Thu)	15930	16.00 (Thu)
(Sun) 18.00	15929	15929	16.00 (Thu)

Agreed to.

Railway Board

CPTM/NFR
 28/1/16
 P. S. S. S.

CPTM/SR

7364
 3682
 3682
 kms.

SOUTHERN RAILWAY

Minutes of the IRTTC Meeting held at Chennai from 27.1.2016 to 29.1.2016

EXTENSION OF TRAINS

Train No.16181/16182 Chennai Egmore – Manamadurai Silambu Express upto Sengottai

Day	T.No.16181	Stations	T.No.16182	Day
Wed/Sat	20.20	d	MS	Fri/Mon
Thu/Sun	07.30/07.40	a/d	MNM	Thu/Sun
	11.30	a	SCT	Thu/Sun
			d	
			a/d	
			19.50/20.00	
			15.10	

1.	Frequency	Bi-weekly
2.	Distance over extended run	195 kms. over extended run to SCT
3.	Maintenance	Chennai Egmore
4.	Other end attention	Sengottai
5.	Stoppages over extended portion	Narikudi, Tiruchchuli, Aruppukottai, Virudunagar, Tiruttangal, Sivakasi, Srivilliputhur, Rajapalayam, Sankaran Koil, Pamban
6.	Running Time	15 hrs. 10 mts. (MS-SCT) & 14 hrs. 55 mts. (SCT-MS)
7.	Speed	44.95 kmph (MS-SCT) & 45.71 kmph (SCT-MS)
8.	Composition	SLR-2, ACCW-1, ACCN-2, GSCN-6, GS-6 = 17 coaches
9.	No of rakes required.	NIL (extension during lie-over period)

Rake link:

MS	SCT	No. of rakes : One (SR)
16181	16181	repeat
16182	16182	repeat
(Wed) 20.20	11.30 (Thu)	
(Fri) 06.05	15.10 (Thu)	
(Sat) 20.20	11.30 (Sun)	
(Mon) 06.05	15.10 (Sun)	

682	kms.
682	
682	
682	
682	
2728	

Agreed to.

28/1/16
/Railway Board

CPTM/SR

Handwritten signature

SOUTHERN RAILWAY

Minutes of the IR TTC Meeting held at Chennai from 27.1.2016 to 29.1.2016

EXTENSION OF TRAINS

Train No.16343/16344 Thiruvananthapuram – Palakkad Town Amrittha Express up to Madurai

T.No.16343	↑	Stations	↓	T.No.16344
TVC-PGTM-MDU	d	TVC	a	MDU-PGTM-TVC
22.30	a/d	PGTM	a/d	21.40/21.45
08.00/08.05	a	MDU	d	15.30

1.	Frequency	Daily
2.	Distance over extended run to MDU	241 kms. over extended run to MDU
3.	Maintenance	Thiruvananthapuram
4.	Other end attention	Madurai
5.	Stoppages over extended portion	Pudunagaram, Kollengode, Pollachi, Udumalpettai, Palani, Oddanchathram, Dindigul, Kodaikanal Road
6.	Running Time	14 hrs. 45 mts. (TVC-MDU) & 13 hrs. 55 mts. (MDU-TVC)
7.	Speed	41.83 kmph (TVC-MDU) & 44.32 kmph (MDU-TVC)
8.	Composition	SLR-2, ACCW-1, GSCN-8, GS-4 = 15 coaches
9.	No of rakes required.	NIL (extension during lie-over period)

Rake link:

22.30	16343	13.30	MDU
06.25	16344	15.30	MDU
repeat		No. of rakes : One (SR)	

1234
617
617
kms.

Agreed to.

28/1/16
/ Railway Board

CPTM/SR
Hv

SOUTHERN RAILWAY

Minutes of the IRTTC Meeting held at Chennai from 27.1.2016 to 29.1.2016

B. PASSENGER TRAINS.

1. T. No.56819/56820 Kumbakonam - Thanjavur Passenger To Mayiladuturai (Now running as special between MV-KMU-MV as T.No.06039/06040)

T.No.56819 MV-KMU-TJ	↑	Stations	↓	T. No.56820 TJ-KMU-MV
07.15	d	MV	a	20.25
08.00/08.05	a/d	KMU	a/d	19.30/19.35
09.15	a	TJ	d	18.05

1.	Frequency	Daily		
2.	Distance	31 kms.		
3.	Composition	7 GS, 2 SLR = 9 coaches		
4.	Maintenance	PM : VM PFTTR : MV		
5.	stoppages	Tirunageswaram, Tiruvidadimarudur, Aduturai, Narasinganpettai, Kuttalam, Malliyam		
6.	No of rakes required.	NIL		

2. T. No.76851/76852 Tiruchchirappalli - Nagore - Thanjavur Passenger (DEMU) to Karaikal (Now running as special between NCR and KIK as T.No.06852/06851)

T.No.56852	↑	Stations	↓	T.No.56851
16.30	d	TPJ	a	11.30
20.55/21.05	a/d	NCR	a/d	06.20/06.30
21.12	a/d	TMPT	a/d	06.05
21.30	a	KIK	d	06.00

1.	Frequency	Daily		
2.	Distance	10 kms.		
3.	Composition	2 DPC, 6 TC = 8 coaches (DEMU rake)		
4.	Maintenance	PM : TPJ PFTTR : KIK		
5.	Stoppages	Tirumalairayanpattinam		
6.	No of rakes required.	NIL		

Agreed to.

28/1/16
Railway Board

CPTM/SR

28/1/16

SOUTHERN RAILWAY

Minutes of the IRTTC Meeting held at Chennai from 27.1.2016 to 29.1.2016

3. T.No.56665/56666 Kasaragod - Mookambika Road Bynoor Passenger to Kannur (presently running as special T.No.0666/06665 between KQG-CAN)

T.No.56666 KSG-BYNR	↑	Station	↓	T.No.56666 BYNR-KSG
04.00	(d)	Kannur	(a)	20.55
06.20/06.40	(a/d)	Kasaragod	(a/d)	18.10/18.40
11.50	(a)	Mookambika Road Bynoor	(d)	13.05

1. Frequency	Daily
2. Distance	86 kms. over extended run to Kannur
3. Composition	14 GS, 2 SLR = 16 coaches
4. Maintenance	PM : MAQ PFTTR : CAN
5. Stoppages	All stations between Kasaragod - Kannur
6. No of rakes required.	NIL

4. T.No.76850/76849 Salem - Vridhachalam Passenger to Mayiladuturai.

T.No.76850 SA - VRI	Stations	T.No.76849 VRI - SA
09.40	SA	17.00
12.55	VRI	13.10
14.55	CUPJ	11.43
15.10	T DPR	11.25
17.00	MV	--

1. Frequency	Daily
2. Distance	133 KMs on extended portion.
3. Composition	2 DPC, 6 TC = 8 Coaches
4. Maintenance	PM - TPJ
5. Stoppages	All stations over VRI - CUPJ - MV
6. No of rakes required.	One DEMU rake with toilet facility will be required.
7. Remarks	<ul style="list-style-type: none"> In VRI-CUPJ section, recently Train Nos.56833/56834 were cancelled due to poor patronage. Frequently representations are being received from travelling public for train service between VRI-CUPJ & CUPJ-MV. The train 76850 conveniently connects T. no. 76825 MV-TJ Passenger for TJ/TPJ and T. no. 56878 MV - VM Passenger leaving at 17.45. T. No. 56873 VM-MV Passenger arriving MV at 09.10 conveniently connects T. no. 76849.

Agreed to.

/ Railway Board

CPTM/SR

3. Rake link for Extension of passenger up from VRI to MV.

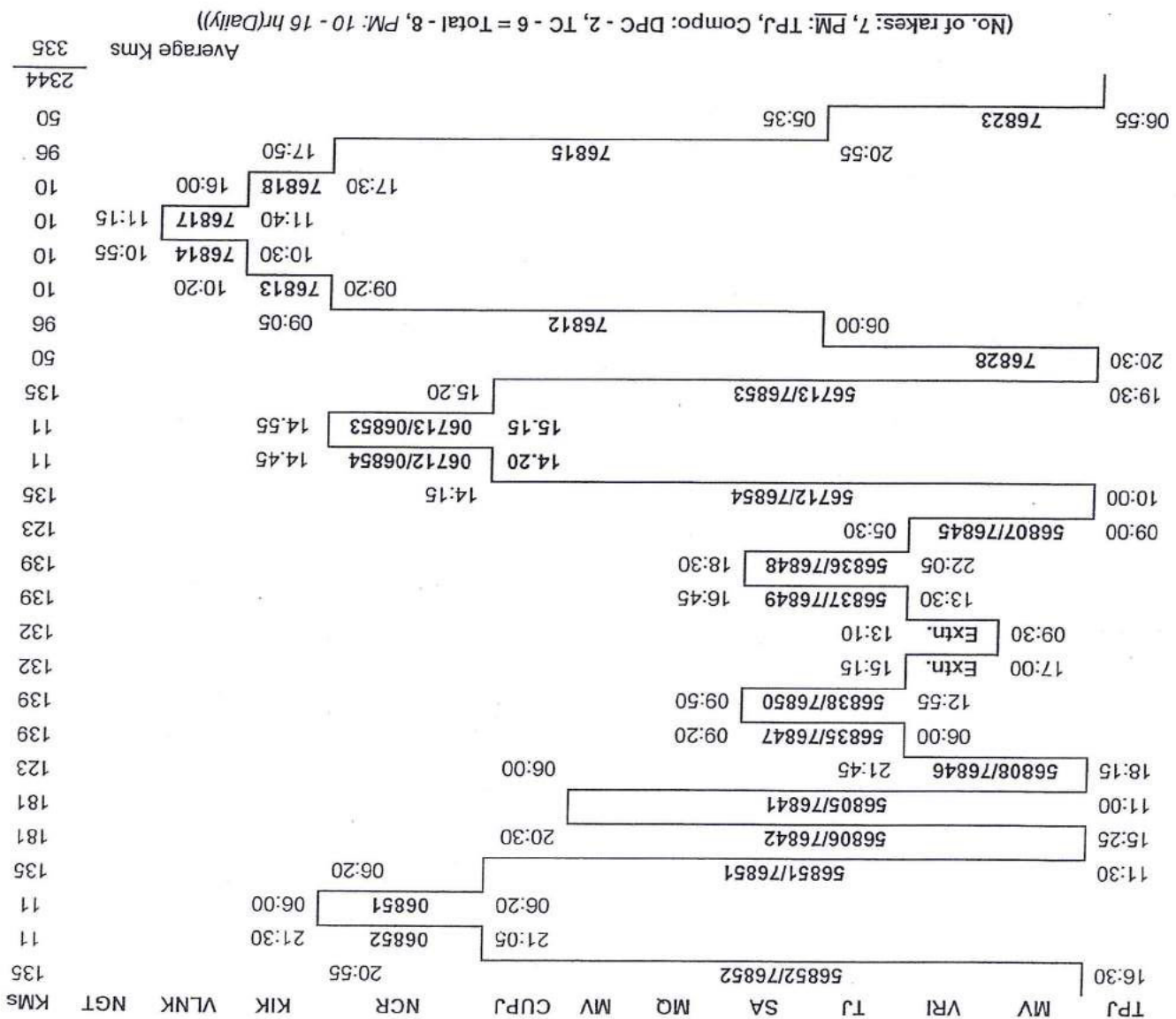

(No. of rakes: 7, PM: TPJ, Compo: DPC - 2, TC - 6 = Total - 8, PM: 10 - 16 hr(Daily))

Average Kms

335

2344

50

96

10

10

10

10

96

50

135

11

11

135

123

139

139

132

132

139

139

123

181

181

135

11

11

135

SOUTHERN RAILWAY

Minutes of the IRRTC Meeting held at Chennai from 27.1.2016 to 29.1.2016

INCREASE IN FREQUENCY OF TRAINS ; RB AGENDA 139

A. EXPRESS TRAINS

1. T.No.16181/16182 Chennai Egmore - Manamadurai - Chennai Egmore Silambu Express From Bi-Weekly To Tri-Weekly And Extension Upto Sengottai.

Existing days of service	Proposed days of service	Present Timings	Proposed Timings	Station	Existing days of service	Proposed days of service
Wed & Sat	Mon, Wed & Sat	20.20	20.15	MS	Fri & Mon	Wed, Fri & Mon
Thurs & Sun	Tue, Thu & Sun	07.30	07.30	MNM	Thurs & Sun	Tue, Thu & Sun
Thurs & Sun	Tue, Thu & Sun	11.30	11.30	SCT	Thurs & Sun	Tue, Thu & Sun

1. Frequency	From Biweekly to Triweekly
2. Composition	No change - existing
3. Maintenance	PM - MS, PFR - SCT
4. Stoppages	Existing stoppages
5. No of rakes required.	NIL

B. PASSENGER TRAINS

1. T.No.56105/56106 & T.No.56107/56108 Salem - Karur - Salem Passenger From 6 Days A Week (except Sunday) To Daily.

T.No.56105	T.No.56107	↑	Station	↓	T.No.56108	T.No.56106
06.00	17.30	(d)	SA	(a)	21.50	10.30
06.55	18.25	(d)	NMML	(d)	20.25	09.05
08.10	19.30	(a)	KRR	(d)	19.50	08.30

1. Frequency	From 6 days a week to Daily.
2. Composition	No change - existing
3. Maintenance	PM - ERODE
4. Stoppages	Existing stoppages
5. No of rakes required.	NIL

Agreed to

Railway Board

28/1/16

CPTM/SR

Handwritten signature

SOUTH CENTRAL RAILWAY

**Confidential
Tentative**

Minutes of IRTTC meeting held at Chennai on 27-01-2016 to 29-01-2016.

Railway Board agenda item No. 27 : Introduction of new Train between Guntur - Guwahati Express (WEEKLY)

Station	Station	Station	Station	Station	Station	Station	Station
GNT - GHY ↑	(Fri)	Fri 12.45	D	GNT	A	03.00 Wed	GHY - GNT ↓
		19.23/25	A/D	DVD	A/D	18.18/20	
		06.08/10	A/D	BHC	A/D	06.35/37	
		11.00	D	BTNG	D	01.40	
		17.40/50	D	MLDT	D	19.20/35	
		Sun 08.15	A	GHY	D	06.15 Mon	
		2305		Distance		2305	
		52.98		Avg Speed		51.50	
		43hrs30m		OAT		44hrs45m	

Days of service		Ex GNT : Fri		Ex GHY: Mon	
Days of service	SCR	BZA,EE,TDD,RJY,SLO,TUNI,AKP			
Stoppages	ECOR				
	SER	BLS, KGP	(NO TRACTION CHANGE OVER SER)		
	ER		NO traction change can be done over CR - Bawl in charalike, inturban sector for buy		
	NFR				
Primary Maintenance	PM	GHY			
Secondary Maintenance	GHY				
Loco required	One AC				
Rake required	One Rake				
Composition	1GSLR, 1GSLRD, 6GS, 9WGSCN, 2WGACGN, 1WGACGW, 1WCB = 21				
Repercussions (if any)					
Likely date of introduction/extension	RB to decide				

CPTM/SCR
 29.1.16
 CPTM/ER
 29/1/16
 CPTM/NFR
 29/1/16
 RB
 GHY has put constraints, the train may be extended upto 5L. Two rakes would be suggested.

CPTM/ECOR
 CPTM/SER
 at Bawl
 traction change should be made

27
 Introduction of new Train between Guntur - Guwahati Express (WEEKLY)

SOUTH CENTRAL RAILWAY

**Confidential
Tentative**

Minutes of IRTTC meeting held at Chennai on 27-01-2016 to 29-01-2016.

Railway Board agenda item No. 26 : Introduction of new Train between Tirupati - Amaravati Express (WEEKLY)

TPTY-AMI ↑	(Thu)	Station	AMI - TPTY ↓
Thu 07.15	D	TPTY	A
09.18/20	A/D	GDR	A/D
12.41/43	A/D	TEL	A/D
13.15/50	A/D	GNT	A/D
20.20/30	A/D	SC	A/D
04.00/20	A/D	PRLI	A/D
13.15/35	A/D	AK	A/D
Fri 15.00	A	AMI	D
1387		Distance	1387
43.69		Avg Speed	41.40
31 hrs 45 m		OAT	33 hrs 30m

Days of service	EX TPTY: Thu	EX AMI: Fri
Stoppages	SCR	RU, KHT, VKI, GDR, NLR, KVZ, OGL, CLX, TEL, GNT, SAP, PGR, NDKD, MRGA, NLDA, CHZ, SC, BMT, LPI, VKB, ZB, BIDR, BHLK, UDGR, LTRR, PNF, PRLI, GNH, PBN, PAU, BMF, HNL, WHM
	CR	AK, BD, MZR,
Primary Maintenance	TPTY	
OEM/TA	AMI	
Loco required	One Diesel	
Rake required	One Rake	
Composition	1GSLR, 1GSLRD, 6GS, 7WGSCN, 1WGACCN, 1WGACW, = 17	
Repercussions (if any)	RB to decide	
Likely date of introduction/extension		

CPTM/SCR
29.1.16
RB

CPTM/CR
29.1.16

CPTM/SCR
29.1.16

RB /
24/1/16

Days of service	EX-MTM - SUN,TUE,FRI EX-DMM - MON,WED,SAT	Stoppages	GDV,BZA,MAG,GNT,NRT,VKN,KCD, DKD,MRK,CBM,GID,NDL,BMH,DHNE,GTL,GY ,ATP	Primary Maintenance	MTM	Secondary Maintenance/OEM	DMM	Distance (One side) in case of extension please indicate the extended distance (also)	Average Speed	Total time on run (In case of extension please indicate the TOR upon extension)	Loco required	01 WDP 4D	Loco required from Board	01 WDP 4D	Rake required	01 RAKE REQUIRED	Rake required from Board	01 RAKE REQUIRED	Composition (for new services)	02-SLR, 06-GS, 10-GSCN, 01-ACCW, 02-ACCN = 21	Repercussions (if any)	T.No 57425 ARR to GTL at 20.05 instead of 19.30	Likely date of introduction/extension	BOARD TO DECIDE
-----------------	--	-----------	---	---------------------	-----	---------------------------	-----	--	---------------	---	---------------	-----------	--------------------------	-----------	---------------	------------------	--------------------------	------------------	-----------------------------------	--	------------------------	---	--	-----------------

Timings A/D	Stations	Timings A/D
15.50	MTM	10.30
18.15/30	BZA	07.10/07.25
19.30/35	GNT	06.00/10
02.10/15	NDL	22.30/35
05.20/40	GTL	18.50/19.15
08.45	DMM	16.10

Minutes of IRITC meeting held at Chennai on 27-01-2016 to 29-01-2016.
Introduction of new Train between MTM - DMM EXPRESS (Tri-WEEKLY)

Minutes of IRTC meeting held at Chennai on 27-01-2016 to 29-01-2016.

Increase in frequency of Train No 12719/12720 HYB-AII-HYB
 Railway Board agenda item No : 11 under increase in frequency

Present Days of Service	EX: HYB
Proposed days of service	EX: HYB
	MON, WED, THUR
	EX AII
	WED, FRI
	WED, FRI, SAT

One additional rake of 23 coaches with loco required and existing halts will remain same.

Composition: 2SLR, 6GS, 11GSCNY, 3ACCN, 1ACCW Total 23 coaches.

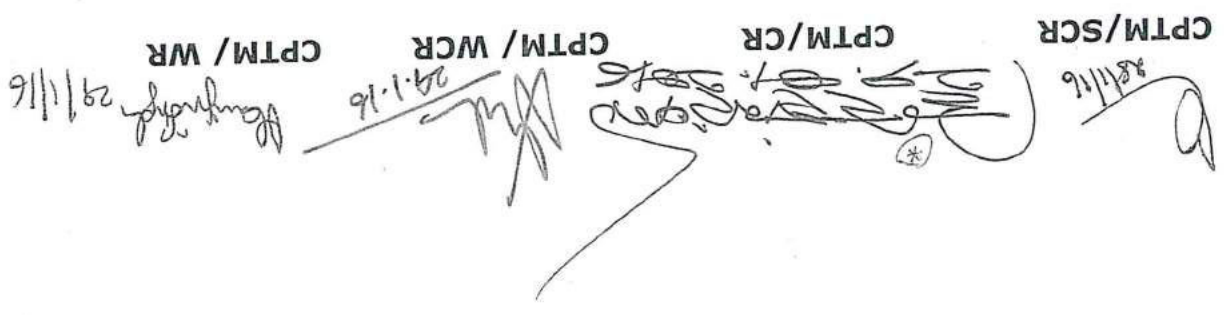

29/1/16 /RB

[Signature]
 CPTM/NWR 25/1/16

* Remarks :- feasible on existing coaches - feasible on existing unit & parts in RBP

28.1.16

RB
28/1/16

Days of service	EX-BZA- SAT, MON, WED EX-DMM- SUN, TUE, THUR	Stoppages	PKO, BVRM, GDV, BZA, MAG, GNT, NRT, VKN, KCD, DKD, MRK, CBM, GID, NDL, BMH, DHNE, GTL, GY, ATP
Primary Maintenance	NS/BZA	Secondary Maintenance/OEM	DMM
Distance (One side) in case of extension please indicate the extended distance (also)	673 KM	Average Speed	
Total time on run (In case of extension please indicate the TOR upon extension)		Loco required	01 WDP 4D
Loco required from Board	01 WDP 4D	Rake required from Board	01 RAKE REQUIRED
Rake required from Board	01 RAKE REQUIRED	Composition (for new services)	02-SLR, 06-GS, 10-GSCN, 01-ACCW, 02-ACCN = 21
Repercussions (if any)	NIL	Likely date of introduction/extension	BOARD TO DECIDE

Timings A/D	Stations	Timings A/D
14.30	NS	11.25
18.15/30	BZA	07.10/07.25
19.30/35	GNT	06.00/10
02.10/15	NDL	22.30/35
05.20/40	GTL	18.50/19.15
08.45	DMM	16.10

Minutes of IRTTC meeting held at Chennai on 27-01-2016 to 29-01-2016.
Introduction of new Train between NS/BZA - DMM EXPRESS (Tri-WEEKLY)

Minutes of IRTTC meeting held at Chennai on 27-01-2016 to 29-01-2016.

SCR Item No. C1 : Increase in frequency of Train No.17009/17010 Bidar-Hyderabad/Secunderabad-Bidar 6 days Express to Daily.

T.No.	Present Days of Service	Proposed Days of service
17010 Secunderabad - Bidar	6 Days except Sat	7 Days
17009 Bidar-Hyderabad	6 Days except Sun	7 Days

CPTM/SCR
28/1/16

28/1/16
/RB

Minutes of IRTTC meeting held at Chennai on 27-01-2016 to 29-01-2016.

Extension of T.No. 57477/57478 TPTY-GTL-TPTY passenger to RC

T.No. 57477 TPTY-GTL-RC

Station	Present		Proposed	
	Arr.	Dep.	Arr.	Dep.
TPTY		22.30		22.30
GTL	09.05	-	09.05	09.30
RC	-	-	12.45	-

Commercial stoppage : All stations between GTL-RC

T.No. 57478 RC-GTL-TPTY

Station	Present		Proposed	
	Arr.	Dep.	Arr.	Dep.
RC	-	-	-	14.00
GTL		18.00	17.30	18.00
TPTY	06.20	-	06.20	-

Commercial stoppage : All stations between RC-GTL

Justifications

1. There is no passenger train during day time to Raichur to cater the needs of general public.
2. This will also help to avoid extra shunting movement at Guntakal besides occupying a running line.

CPTM/SCR
29/1/16

RB
28/1/16

Confidential

SOUTH CENTRAL RAILWAY

Tentative

Minutes of IRTTC meeting held at Chennai on 27-01-2016 to 29-01-2016.

Cancellation of T.No. 57131 BMO-HYB passenger.

Due to short termination and diversion of T.No. 57129 BJP - BMO to HYB the T.No. 57131 BMO - HYB proposed cancelled.

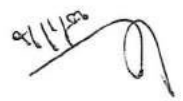

CPTM/SCR

To be approved
by Board (MT).
RB 28/1/16

Minutes of IRTC meeting held at Chennai on 27-01-2016 to 29-01-2016.

Short Termination/Diversion of T.No. 57129 BJP-BMO passenger.

Due to - Platform congestion at BMO and Path construction in SC-BMO section

Station	Present		Proposed	
	Arr.	Dep.	Arr.	Dep.
BJP	18.30	18.30		18.30
SC	08.00	08.05	----	----
BMO	08.45		--	--
HYB	---		09.00	

No change in existing timings on SAK SCRly.

[Signature]
CPTM/CR

[Signature]
CPTM/SWR

[Signature]
CPTM/SCR

To be approved by board(MT)

[Signature]
28/1/16
/RB

Confidential

SOUTH CENTRAL RAILWAY

Tentative

Minutes of IRTTC meeting held at Chennai on 27-01-2016 to 29-01-2016.

Short Termination of T.No. 77676/77677 MRGA-PGRL-MRGA at NDKD

To ease platform congestion of Piduguralla (PGRL) station T.No. 77676/77677 Miryalguda-Piduguralla-Miryalguda DEMU services will be short terminated at Nadikudi station.

T.No. 77676/77677 Miryalguda-Piduguralla-Miryalguda DEMU

Station	Present		Proposed	
	Arr.	Dep.	Arr.	Dep.
MRGA	-	23.25	-	23.25
NDKD	00.35	02.14	00.35	-
PGRL	02.45	-	-	-

To be approved by Board (MT).

RB
28/1/16

CPTM/SCR
28.1.16

Confidential

SOUTH CENTRAL RAILWAY

Tentative

Minutes of IRTTC meeting held at Chennai on 27-01-2016 to 29-01-2016.

Short Termination of T.No. 77645 UR-SC at KCG, to return track empty
also movement from KCG. SC - KCG.

T.No. 77645 Umdanagar to Kacheguda DEMU

Station	Present		Proposed	
	Arr.	Dep.	Arr.	Dep.
UR	-	17.20	-	17.50
KCG	17.58	18.00	18.35	-
SC	18.45	-	-	-

CPTM/SCR

24/1/16

RB

24/1/16

Minutes of IRTTC meeting held at Chennai on 27-01-2016 to 29-01-2016.

Cancellation of DOUBLE DECKER T.No. 22117/22118 GNT-KCG-GNT and

T.No. 22119/22120 KCG-TPTY-KCG

T.No. 22117/22118 GNT-KCG-GNT
EX: GNT (TUE, FRI) KCG (TUE, FRI)

Timings ARR	DEP	STATIONS	Timings ARR	DEP
17.55	12.40	GNT	10.40	05.30
		KCG		

T.No. 22119/22120 KCG-TPTY-KCG

EX: KCG (WED, SAT) EX: TPTY (THUR, SUN)

Timings ARR	DEP	STATIONS	Timings ARR	DEP
18.15	06.45	KCG	17.15	05.45
		TPTY		

The occupancy of these trains right from their introduction is 8.65% for GNT services and 15.65% for the Tirupathi services on an average, during the peak and non peak seasons combined.

Ref No:- (i) GM/SCR DO addressed to MT/NDRB vide DO No. T.454/DD/2014/1 dated 23.12.2014.

(iii) Railway Board Msg, No.2014/CHG/37/3 dated 02.01.2015

It will be put up for approval of competent authority

28/1/16 / RB

CPTM/SCR
28/1/16

Confidential

SOUTH CENTRAL RAILWAY

Tentative

Minutes of IRTTC meeting held at Chennai on 27-01-2016 to 29-01-2016.

28
Railway Board Item No. 32: Introduction of new Train between Guntur -
Macherla-Guntur (Daily) Passenger

Timings	Stations	Timings
12.30 D	GNT	19.45
14.55/15.05 A/D	NKD	17.25/17.30
16.00 A	MCLA	16.30

Days of service	Daily	
Stoppages	NLPD, BDPL, MDPD, SRPM, LIM, PKPU, GPDE, SAP, REM, BMKD, PGRL, TMLU, GZA, RCA	
Primary Maintenance	GNT	
Secondary Maintenance/OEM		
Distance (One side) in case of extension please indicate the extended distance (also)	130	
Average Speed	38.14 (Both Directions)	
Total time on run (In case of extension please indicate the TOR upon extension)		
Loco required	One Diesel loco	
Rake required	One rake required from RB	
Composition (for new services)	2SLRs, 10 GS	
Likely date of introduction	RB to decide	

CPTM/SCR

28/1/16

28/1/16 /RB

MINUTES OF THE TIME TABLE MEETING HELD AT CHENNAI

FROM 27/01/2016 TO 29/01/2016

SCR AGENDA ITEM

Item: Increase in frequency of 11045 KOP-DHN from Weekly to Bi-weekly
4 times weekly

Existing Timings and days:-

Day	Ex Kolhapur	Station	EX Dhanbad	Day	Ex Kolhapur	Station	EX Dhanbad	Day
Thu	23.45	D	Kolhapur	A	03.45		EX Dhanbad	Thu
Fri	14.55	Th	Ankai	Th	12.20			Wed
Sat	03.03/03.05	A/D	Pimpalkutti	Th	22.25			Tue
	13.30	Th	Juharpur	Th	11.05			
Sat	22.45	Th	Manikpur	Th	02.35			Tue
Sun	05.31	Th	NEW C	Th	20.24			
Sun	12.00	A	Dhanbad	D	13.55			Mon

Frequency : Weekly : Ex Kolhapur - Thursday
 Ex Dhanbad - Monday

CR Remarks: NOT FEASIBLE as

1. Pit and stabling constraints at Kolhapur.

2. Existing timings of 11045/11046 at Ankai are cutting the only corridor block available in ANK-MMR section.

3. The path of 11045 KOP-DHN in MJRI-ET section of Central Railway is shared by 16359, 15119 and 22403. The path of 11046 DHN-KOP in ET-MJRI section is shared by 12194, 22684, 16360 and 15120.

[Handwritten signatures and initials]

C.P.T.M./CR C.P.T.M./SCR C.P.T.M./WCR C.P.T.M./NCR C.P.T.M./ECR

RAILWAY BOARD
 28/01/2016

Minutes of IRTTC meeting held at Chennai on 27-01-2016 to 29-01-2016.

Diversion of T.No. 67251 BZA-TEL (MEMU) passenger via Guntur

Station	Present		Proposed	
	Arr.	Dep.	Arr.	Dep.
BZA		05-00		04-10
GNT	-	-	05-10	05-20
TEL	05-50	-	06-00	-

Commercial Stoppages KCC,MAG,NBR,PDKN,GNT,VIA,SIL,TEL

- 1) The diversion of the above train via GNT and TEL, it will become a connecting train for Vijayawada, Mangalagiri, Namburu people to catch the T.No. 12747 GNT-SC Palnadu express to go to MRGA/NLDA areas.
- 2) It will become a connecting train to GNT area passengers to board T.No. 12711 BZA-MAS Pinakini express at TEL.
- 3) There is no change in the original rake link of T.No. 67253 from TEL-BZA scheduled departure at 06.10hrs.

4) T.No 67298 BZA-GDR DM which leaves 05.10 hrs
 will catch the ~~express~~ passengers. Only on stoppage
 (5) i.e. Kolarakur (Half) will not be there.

CPTM/SCR
 22/1/16

RB
 22/1/16

Minutes of IRTC meeting held at Chennai on 27-01-2016 to 29-01-2016.

SCR Item No. A. 14: Introduction of new Train between Tirupati - Nagarjola weekly Exp

TPTY-NSL	Stations	NSL-TPTY
Fri 07.30	D	TPTY
09.18/20	a/d	GDR
12.41/43	a/d	TEL
13.15/50	a/d	GNT
20.15/25	a/d	SC
04.00/20	a/d	PRLI
11.55 Sat	A	NSL
1331		1331
46.83		Avg Speed
28 hrs 25m		Over all Time

Days of service	Ex TPTY : Fri Ex : NSL Sat	Stoppages	RU,KHT,GDR,NLR, OGI, BPP, TEL, GNT, SAP, PGRL, NDKD, MRGA, NLD, SC, BMT, LPI, SKP, VKB, ZB, BIDR, BHLK, UDGR, LTRR, PNF, PRLI, GNH, PBN, MVO, SELU, PTU, JAWB. CHZ.
Primary Maintenance	TPTY	Secondary Maintenance/OEM	OEM : NSL
Distance (One side) in case of extension please indicate the extended distance (also)	1331	Average Speed	
Total time on run (In case of extension please indicate the TOR upon extension)		Loco required	
Rate required	Lie over rake 17417/17418 TPTY-SNSI Weekly Exp	Composition (for new services)	2GSLR, 6GS, 7WGSN, 1WGACN, 1WGACW, = 17
Repercussions (if any)		Likely date of introduction/extension	

CPTM/SCR

28/1/16

RB

28/1/16

Confidential

SOUTH CENTRAL RAILWAY

Tentative

Minutes of IRTC meeting held at Chennai on 27-01-2016 to 29-01-2016.

Introduction of new Train between HYB-SVDK-HYB (weekly express)

Days of service	Timings A/D	Stations	Timings A/D	Days of service
THU	15.10	HYB	21.10/20	MON
FRI	04.50/05.00	BPQ	22.40/50	
	08.30/35	BINA	13.10/15	
	16.15	PWL	08.25/30	SUN
SAT	03.15	SVDK	10.20	SAT

Days of service	EX-HYB:THUR	EX-SVDK: SAT
Stoppages	SCR: SC,KZJ,RDM,MCI,SKZR. CR : BPQ,CD,NBP,SEGM,BZU,NGP WCR:ET,HBJ NCR: JHS,GWL,AGC,MTJ NR: NDLS,PMP,UMB,LDH,PTKC,JAT,UHP	
Primary Maintenance	HYB	
Secondary Maintenance	SVDK	
Distance (One side) in case of extension please indicate the extended distance (also)	2330 KM	
Average Speed	64.5KMPH	56.5KMPH ✓
Total time on run (In case of extension please indicate the TOR upon extension)	36.05 hrs	41.10 hrs
Loco required	01 WAP7	
Loco required from Board	01 WAP7	
Rake required	01 RAKE REQUIRED	
Rake required from Board	01 RAKE REQUIRED	
Composition (for new services)	02-SLR, 06-GS, 01 FACCW, 01ACCW, 02 ACN, 09 GSCN, 01 WCB = 22	
Repercussions (if any)	NIL	
Likely date of introduction/extension	BOARD TO DECIDE	

CR numbers:- 12803 required 5" earlier at BPQ/SCZY.

CPTM/SCR

CPTM/CR

CPTM/WCR

CPTM/NCR

CPTM/NR

/RB

29-1-16

28/1/16

29/1/16

✓

Tentative

Confidential

Minutes of meeting in IRTTC held at Chennai from 27.01.2016 to

29.01.2016.

Tirupati/ Hyderabad - Vasco - Hyderabad/ Tirupati Weekly Express.

TPTY/ HYB - VSG	Stations	VSG - HYB/ TPTY
11.30 (Mon)	Tirupati	09.25 (Wed)
09.35 (Mon)	Hyderabad	11.00 (Wed)
17.40/ 18.10	Guntakal	01.40/ 02.20
19.20/ 19.25	Bellary	00.50/ 00.55
23.45/ 23.50	Hubballi	20.05/ 20.20
06.00 (Tue)	Vasco	14.30 (Tue)
18.30 hrs/ 20.25 hrs	Run Time	18.55 hrs/ 20.30 hrs

Composition :

Ex: TPTY : 1 ACW, 1 ACN, 3 GSN, 3 GS, 2 SLR = 10 coaches

Ex: HYB : 1 ACW, 1 ACN, 3 GSN, 3 GS, 2 SLR = 10 coaches

Maintenance : PM at TPTY/ HYB with RBPC.

Distance : Ex. TPTY - VSG = 780 Km. ; Ex. HYB - VSG = 873 Km.

Speed : Ex. TPTY = 42.16/ 41.23 kmp/h, Ex. HYB = 42.75/ 42.58 kmp/h.

Halts :

On SCR : KOU, RJP, HX, YA, MOO, TU, GY, GTL, AD, MALM, RC, YG, CT, MGR, SEM, TDU, VKB, LPI, BMT;

On SWR : BAY, TNGL, HPT, KBL, GDG, UBL, LD, CLR, MAO, DWR, SVM, QLM, LWR.

Loco Required : 2 WDP4 D

No. of rakes : ONE (20 coaches)

Railway Board is requested to run the train with split BPC.

Date of Introduction : Railway Board to decide.

CPTM/ SCR

28-1-16

In reply to starred Parliamentary Qns. given by Hon'ble Mkr in the Parliament to start com/KRCL Vasco-TPTY exp to be diverted from that section to accommodate this train.

29/1/16

to accommodate this train. to be diverted from that section to start com/KRCL Vasco-TPTY exp

CPTM/ SWR

29/1/16

Due to that section construction in LD-VSG section no new train can be added. Moreover, connection to 12719 or VSG is being given by 17416 of CD for connecting passenger to TPTY.



IRCTC-2016

IRCTC CRIS

Railway: SER
 Minutes of the IRCTC meeting held at Chennai from 27-01-2016 To 29-01-2016
 Proposal ID - SER151600006
 Proposal Type - NEW TRAIN SERVICE

Confidential

Timings

TRAIN No/ PROPOSAL	ARRIVAL	DEPARTURE	STATIONS	ARRIVAL	DEPARTURE	TRAIN No/ PROPOSAL
SER15160000601	21:18:00	17:15:00	SRC	23:30:00	19:07:00	SER15160000602
	21:18:00	21:20:00	BHC	19:05:00	19:07:00	
	07:00:00	07:00:00	DVD	08:25:00	08:25:00	
	18:30:00	18:45:00	RU	20:30:00	20:45:00	
	06:15:00	06:15:00	ERS	08:50:00	08:50:00	

Stoppages

ZONE	Commercial	OPERATING
SER	KGP, BLS	
ECOR	BHC, CTC, BBS, KUR, BAM, VSKP	
SCR	RJY, BZA, OGL, NLR, RU	RU
SR	KPD, SA, ED, CBE, PGT, TCR	

Both
 Main
 Reverse

Day Of Operating UP/DN

Distance

Total time of run UP/DN

Average speed UP/DN

Add Reversals

Repercussion

Primary Maintenance

Secondary Maintenance

Loco Requirement

Loco Requirement from Board

Rake Requirement

Rake Requirement from Board

Composition is case of new service

Likely date of Introduction

Remarks:

01/07/2015
 SLRD-2, WGSCN-11, WGACCN-3, WGACCN-2, WGCW-2, WGCW-1 = 19 Coaches
 SRC
 ERS
 One WAP4
 One WAP4
 Loco Requirement from Board
 One WAP4
 Loco Requirement from Board
 Rake Requirement from Board
 One
 Rake Requirement from Board
 One

CPTM/SER
 CPTM/ECOR
 CPTM/SCR
 CPTM/SR
 CPTM/SR
 RB
 29.1.16
 29.1.16
 29.1.16

SUVIDHA EXPRESS



IRITC-2016

IRITC CRIS

Railway: SER
 Minutes of the IRITC meeting held at Chennai from 27-01-2016 To 29-01-2016
 Proposal ID- SER151600034
 Proposal Type- NEW TRAIN SERVICE

Confidential

Timings

TRAIN No/ PROPOSAL	ARRIVAL	DEPARTURE	STATIONS	ARRIVAL	DEPARTURE	TRAIN No/ PROPOSAL
SER15160003401	18:30:00	18:30:00	HWH	18:15:00	18:15:00	SER15160003402
	02:00:00	02:00:00	JSG	10:20:00	10:20:00	
	11:15:00	11:25:00	NGP	01:25:00	01:30:00	
	02:45:00		PUNE		10:30:00	

Stoppages

ZONE	Commercial	OPERATING
ER		
SER	*GP TATA	
SECR	/BSP	
CR	NGP, BSL, PVR, MK	

Both
 Main
 Reverse

Day Of Operating UP/DN
 Distance
 Total time of run UP/DN
 Average speed UP/DN
 Add Reversals
 Depreciation
 Primary Maintenance
 Secondary Maintenance
 Loco Requirement
 Loco Requirement from Board
 rake Requirement
 rake Requirement from Board
 Composition is case of new service
 Likely date of Introduction

2044 / 2026
 32:15:00 / 31:45:00
 63 / 64
 SRC
 PUNE
 2 WAP4
 2 WAP4
 Loco Requirement from Board
 rake Requirement
 rake Requirement from Board
 LMLRRM-2, LWAC-1, LWACCW-3, LWACCN-10, LWCBAC-1 = 17 Coaches
 01/07/2016

(Weekly)
 29-1-16
 29-1-16
 29-1-16

CPTM/SER
 CPTM/SECR
 CPTM/CR
 / RB
 29/1/16
 29/1/16
 29/1/16

Remarks:



IRCTC-2016

IRCTC CRIS

Railway: SER

Confidential

Tentative Proposal
 Minutes of the IRCTC meeting held at Chennai from 27-01-2016 To 29-01-2016
 Proposal ID - SER151600009
 Proposal Type - NEW TRAIN SERVICE

Timings

TRAIN No/ PROPOSAL	ARRIVAL	DEPARTURE	STATIONS	ARRIVAL	DEPARTURE	TRAIN No/ PROPOSAL
SER15160000901	22:15:00	22:15:00	TATA	06:00:00	06:00:00	SER15160000902
	23:40:00	23:42:00	PRR	02:21:00	02:23:00	
	00:38:00	00:40:00	JOC	01:45:00	01:47:00	
	02:30:00	02:50:00	ASN	00:50:00	01:10:00	
	04:48:00	04:50:00	JSM	22:38:00	22:40:00	
	06:40:00	06:45:00	JAJ	21:25:00	21:30:00	
	07:43:00	07:55:00	KIUL	19:10:00	19:12:00	
	09:30:00	09:50:00	BJU	17:17:00	17:20:00	
	12:30:00		DBG		15:00:00	

Stoppages

ZONE	Commercial	OPERATING
SER	PRR, JOC	
ER	ASN, JSME	ASN

Both
 Main
 Reverse

Day Of Operating UP/DN

Distance

Total time of run UP/DN

Average speed UP/DN

Add Reversals

Repercussion

Primary Maintenance

Secondary Maintenance

Loco Requirement

Loco Requirement from Board

Track Requirement

Track Requirement from Board

Composition in case of new service

Likely date of Introduction

Remarks:

Utilizing the lie-over period of 18111/18112 TATA-BYPL WKly Exp.

CPTM/SER

CPTM/ER

CPTM/ECR

/RB

NOT FEASIBLE

Not feasible as ECRs
 ECR's timings not
 agreeable
 (Dropped)



IRRTC-2016

CRIS

Railway: SER
Minutes of the IRTTC meeting held at Chennai from 27-01-2016 To 29-01-2016
Proposal ID- SER151600004
Proposal Type- NEW TRAIN SERVICE

Confidential

Tentative Proposal

Timings

TRAIN No/ PROPOSAL	ARRIVAL	DEPARTURE	STATIONS	ARRIVAL	DEPARTURE	TRAIN No/ PROPOSAL
SER15160000401	23:05:00	19:00:00	SRC	10:00:00	05:10:00	SER15160000402
	23:07:00	23:07:00	BHC	05:08:00	05:10:00	
	09:40:00	09:40:00	DVD	17:50:00	17:50:00	
	21:06:00	21:08:00	GDR	07:15:00	07:20:00	
	23:30:00	23:30:00	MAS		04:45:00	

Stoppages

ZONE	Commercial	OPERATING
SER	KGP, BLS	
ECOR	BHC, CTC, BBS, KUR, BAM, VZM, VSKP	
SCR	SLO, EE, BZA, OGL, NLR, N-2, GDR, AVP, KAY, MAD, BPP	
SR	SPE	

Both
 Main
 Reverse

Day Of Operating UP/DN

Distance 1657

Total time of run UP/DN 28:30:00 / 29:15:00

Average speed UP/DN 58 / 57

Add Reversals

Repercussion

Primary Maintenance

Secondary Maintenance

Loco Requirement

Loco Requirement from Board

One WAP4

Rake Requirement

One

Rake Requirement from Board

SLR-2, GS-18 = 20 Coaches

Likely date of Introduction

01/07/2016

Remarks:

CPTM/SER *[Signature]*
 CPTM/ECOR *[Signature]*
 CPTM/SCR *[Signature]*
 CPTM/SR *[Signature]* 29.1.16 RB
 29/1/16

JANSAADHARAN EXPRESS



IRTTIC-2016



Confidential

Railway: SER
Minutes of the IRTTC meeting held at Chennai from 27-01-2016 To 29-01-2016
Proposal ID- SER151600027
Proposal Type-CHANGE IN FREQUENCY
Tentative Proposal

Timings

TRAIN No/ PROPOSAL	ARRIVAL	DEPARTURE	STATIONS	ARRIVAL	DEPARTURE	TRAIN No/ PROPOSAL
18007	18:48:00	18:50:00	SRC	09:15:00	09:17:00	18008
	18:35:00	18:35:00	SHM	09:32:00	09:32:00	
	20:38:00	20:43:00	KGP	07:15:00	07:20:00	
	22:08:00	22:28:00	ROP	05:24:00	05:42:00	
	23:50:00		VZR (Bhowanipur)		04:05:00	

Stoppages

ZONE	Commercial	OPERATING
SER	SRC, PKU, KGP, BLDA,	JER, BTS, ROP

Both
 Main
 Reverse

Day Of Operating UP/DN

M,T,W,T,F,-,S / M,T,W,T,F,S,-

Distance

216

Total time of run UP/DN

05:15:00 / 05:27:00

Average speed UP/DN

41 / 40

Add Reversals

Repercussion

Primary Maintenance

Secondary Maintenance

Loco Requirement

Loco Requirement from Board

One Rake

Rake Requirement

Rake Requirement from Board

One Rake

Composition is case of new service

01/07/2016

Likely date of Introduction

Remarks:

There will be a temporary Platform Constraints at STM for which the train may have to be short terminated at SRC for the next days of service till such time a new PF (currently under construction) is Commissioned.

J. Srinivas
 CPTM/SER
 28/1/16
 RB
 28/1/16



IRITC-2016

IRITC CRIS

Railway: SER
Minutes of the IRTTC meeting held at Chennai from 27-01-2016 To 29-01-2016
Proposal ID- SER151600014
Proposal Type- EXTENSION
Tentative Proposal

Confidential

Timings

TRAIN No/ PROPOSAL	ARRIVAL	DEPARTURE	STATIONS	ARRIVAL	DEPARTURE	TRAIN No/ PROPOSAL
18404	17:15:00	BBN	CKP	08:55:00		18403
20:10:00	20:15:00	CKP	ROU	06:15:00	06:20:00	
22:00:00					04:45:00	

Stoppages

ZONE	Commercial	OPERATING
SER	BJMD, DPS, KNPS, CBSA,	DPS, KNPS, CBSA
	CKP, CKP	

Both
 Main
 Reverse

M,T,W,T,F,S,S

223

04:45:00 / 04:10:00

47 / 54

- Day Of Operating UP/DN
- Distance
- Total time of run UP/DN
- Average speed UP/DN
- Add Reversals
- Repercussion
- Primary Maintenance
- Secondary Maintenance
- Loco Requirement
- Loco Requirement from Board
- Rake Requirement
- Rake Requirement from Board
- Composition is case of new service
- Likely date of Introduction
- 01/07/2016
- Remarks:

28/1/16
 28/1/16
 CPTM/SER
 /RB



Confidential

Railway: SER
 Minutes of the IRTTC meeting held at Chennai from 27-01-2016 To 29-01-2016
 Proposal ID - SER151600012
 Proposal Type- NEW TRAIN SERVICE
 Tentative Proposal

Timings

TRAIN No/ PROPOSAL	ARRIVAL	DEPARTURE	STATIONS	ARRIVAL	DEPARTURE	TRAIN No/ PROPOSAL
SER15160001201	17:15:00	ADRA	20:00:00	17:38:00	17:39:00	SER15160001202
			SNTD	19:20:00	19:21:00	
			BJE	19:14:00	19:15:00	
			VAA	18:50:00	18:50:00	

Stoppages

ZONE	Commercial	OPERATING
SER	SNKR, RUI, SNTD, BJE, SDMD, BCB, JBO	

Both
 Main
 Reverse

Day of Operating UP/DN

M,T,W,T,F,S,S

Distance

41

Total time of run UP/DN

01:25:00 / 01:10:00

Average speed UP/DN

29 / 35

Add Reversals

NII

Repercussion

TPKR/KGP

Primary Maintenance

NII

Secondary Maintenance

NII

Loco Requirement from Board

NII

Rake Requirement

NII

Rake Requirement from Board

Composition is case of new service

MC-2, TC-6 = 8 Coaches

Likely date of Introduction

01/07/2016

Remarks:

To be integrated with proposed New service between ADRA-MDN MEMU for which one MEMU Rake is required.

28/1/16
 28/1/16
 RB
 CPTM/SER
 [Signature]

To be integrated with proposed new ADRA-MDN, ADRA-MDN, KGP-MDN & ADRA-POR 2A



IRITC-2016

IRITC CRIS

Confidential
Railway: SER
Minutes of the IRTTC meeting held at Chennai from 27-01-2016 To 29-01-2016
Proposal ID- SE1415000016
Proposal Type- NEW TRAIN SERVICE
Tentative Proposal

Timings

TRAIN No/ PROPOSAL	ARRIVAL	DEPARTURE	STATIONS	ARRIVAL	DEPARTURE	TRAIN No/ PROPOSAL
SE141500001601	20:35:10	20:36:10	GRB	22:24:54	22:25:54	SE141500001602
	20:41:20	20:42:20	ANR	22:18:42	22:19:42	
	20:49:50	20:50:50	BGA	22:09:12	22:10:12	
	20:56:50	20:57:50	KSU	22:02:12	22:03:12	
	21:01:32	21:02:32	CHRA	21:57:30	21:58:30	
	21:25:00		PRR		21:50:00	

Stoppages

ZONE	SER	CHRA
Commercial	GRB, ANR, BGA, KSU,	
OPERATING		

Both
 Main
 Reverse

Day of Operating UP/DN M,T,W,T,F,S,S

39

00:55:00

43

Add Reversals

Repercussion

Primary Maintenance

Secondary Maintenance

Loco Requirement

Loco Requirement from Board

Rake Requirement

Rake Requirement from Board

Composition is case of new service

MC-2, TC-6 = 8 Coaches

Likely date of Introduction

Remarks:

28/1/16
 28/1/16
 CPTM/SER
 /RB
[Signature]

To be integrated with proposed new services HARA-MNR, ARA-VAT, KGP-MD N. B
 class HARA-PR & MGR



IRTTTC-2016

IRTTTC CRIS

Railway: SER

Confidential

Minutes of the IRTTC meeting held at Chennai from 27-01-2016 To 29-01-2016

Proposal Type- NEW TRAIN SERVICE

Tentative Proposal

TRAIN No/ PROPOSAL	ARRIVAL	DEPARTURE	STATIONS	ARRIVAL	DEPARTURE	TRAIN No/ PROPOSAL
SE141500001501	13:05:00	13:05:00	KGP	15:10:00	15:10:00	SE141500001502
	13:10:00	13:11:00	GMDN	14:46:00	14:47:00	
	13:15:00	13:16:00	GKL	14:41:00	14:42:00	
	13:40:00		MDN	14:35:00		

Stoppages

ZONE	Commercial	OPERATING
SER	GMDN, GKL	

Both
 Main
 Reverse

Day Of Operating UP/DN

Distance

Total time of run UP/DN

Average speed UP/DN

Add Reversals

Repercussion

Primary Maintenance

Secondary Maintenance

Loco Requirement

Loco Requirement from Board

Take Requirement

Take Requirement from Board

Composition is case of new service

Likely date of Introduction

Remarks:

MC-2, TC-6 = 8 Coaches

01/07/2016

To be integrated with proposed new service between ADRA-MDN MEMU for which one MEMU rake is required.

CPTM/SER
 28/1/16
 RB
 [Signature]



Confidential
 Railway: SER
 Minutes of the IRTTC meeting held at Chennai from 27-01-2016 To 29-01-2016
 Proposal ID - SER151600013
 Proposal Type- NEW TRAIN SERVICE

Timings

TRAIN No./ PROPOSAL	ARRIVAL	DEPARTURE	STATIONS	ARRIVAL	DEPARTURE	TRAIN No./ PROPOSAL
SER15160001301	22:55:00	ADRA		05:05:00	SER15160001302	
	23:06:00	GRB		04:40:00		
	23:14:00	ANR		04:31:00		
	23:23:00	BGA		04:21:00		
	23:30:00	KSU		04:14:00		
	23:35:00	CHRA		04:09:00		
	23:55:00	PRR		04:00:00		

Stoppages

ZONE	Commercial	OPERATING
SER	GRB, ANR, BGA, KSU,	CHRA
	Both	Main
	Reverse	

Day Of Operating UP/DN	M,T,W,T,F,S,S	Distance	39
Total time of run UP/DN	01:00:00 / 01:05:00	Average speed UP/DN	39 / 36
Add Reversals	Nil	Repercussion	Nil
Primary Maintenance	TPKR/KGP	Secondary Maintenance	Nil
Loco Requirement	Nil	Loco Requirement from Board	Nil
Rake Requirement	Nil	Rake Requirement	Nil
Rake Requirement from Board	Nil	Rake Requirement from Board	Nil
Composition is case of new service	TC-6, MC-2 = 8 Coaches	Likely date of Introduction	01/07/2016
Remarks:	To be integrated with proposed new ABRA-MON, PRR-VIA, RCF-MON & ABRA-PRR		

Handwritten notes:
 CPTM/SER
 RB/
 28/1/16



IRTT-C-2016



Railway: SER

Confidential

Tentative Proposal
 Minutes of the IRTTC meeting held at Chennai from 27-01-2016 To 29-01-2016
 Proposal ID- SE141500041
 Proposal Type- NEW TRAIN SERVICE

Timings

TRAIN No/ PROPOSAL	ARRIVAL	DEPARTURE	STATIONS	ARRIVAL	DEPARTURE	TRAIN No/ PROPOSAL
SE14150004101	11:51:00	11:52:00	BQA	15:44:00	15:45:00	SE14150004102
	12:23:00	12:24:00	VSU	15:12:00	15:13:00	
	12:45:00	12:46:00	GBA	14:50:00	14:51:00	
	12:54:00	12:55:00	CDGR	14:40:00	14:41:00	
	13:55:00		MDN		14:10:00	

Stoppages

ZONE	Commercial	OPERATING
SER	MYX, IBL, SRJM, JPH, CN, ANCR, BQA, BXL, KISN, ODM, RSG, VSU, PBA, BGO, GBA, CDGR, SLB, GSL, BUTA	

Both
 Main
 Reverse

Day Of Operating UP/DN

M,T,W,T,F,S,S

Distance

156

Total time of run UP/DN

02:55:00

Average speed UP/DN

53

Add Reversals

NII

Repercussion

TPKR/KGP

Primary Maintenance

NII

Loco Requirement

NII

Loco Requirement from Board

NII

Rake Requirement

One MEMU Rake

Rake Requirement from Board

MC-2, TC-6 = 8 Coaches

Composition is case of new service

01/07/2016

Likely date of Introduction

Remarks:

28/1/16
 CPTM/SER
 JRB
 28/1/16

Proposed new
 One MEMU Rake for the proposed five pairs of MEMU Services, viz. 2 Pairs ADRA-PRR, ADRA-VAH
 ADRA-MBN & KGP-MBN MEMU.

MINUTES OF IRTTC - 2016 AT CHENNAI
FROM 27.01.2016 TO 29.01.2016

South Western Railway Proposal No. A.1

Introduction of Weekend Express (Weekly) from Yesvantpur to Mangalore Jn.

Abstract Timings :

Days of Service	Train No. 16581 (YPR - MAQ) Express	A/D	Station	A/D	Train No. 16582 (MAQ - YPR) Express
Sat	22.50	D	Yesvantpur	A	05.45
Mon	00.05/00.07	A/D	Tumkur	A/D	04.18/04.20
	02.10/02.30	A/D	Arasikere	A/D	02.10/02.37
	03.38/03.40	A/D	Hassan	A/D	00.58/01.00
	10.15 (T)	A/D	Padil	A/D	19.00 (T)
Sun	10.30	A	Mangalore Jn	D	18.50

Composition : 2 SLR/D + 1 ACCW + 1 ACN + 6 GSCN + 6 GS = 16 Coaches

Rake Requirement : Nil [Lie-over rake of T. No. 22683/22684 (YPR - LKO - YPR) Exp.]

Primary Maintenance : YPR with RBPC

Distance : 438 Kms

Days of Service : Ex. YPR on Sat & Ex. MAJN on Sun

Traction : Diesel

Commercial Stoppages : TK, TTR, ASK, HAS, SKLR, SBHR, KBPR, BNTL

Remarks : Timings of affecting Passenger trains will be revised accordingly

Discussed and Agreed

CPTM/SWR/UBL

Railway Board

CPTM/SR/MAS

27/01/16

29/1/16

29.1.16

TRAIN NO 56647 56645

MINUTES OF IRTTC - 2016 AT CHENNAI
FROM 27.01.2016 TO 29.01.2016

South Western Railway Proposal No. A.2
(Rly. Brd. Proposal No. 9)

Hubballi - Chennai - Hubballi (Bi-weekly) Express

Abstract Timings :

Train No. 17324 (UBL - MAS) Express	A/D	Station	A/D	Express	20.30 (Mon, Wed)
11.15 (Tue, Thu)	A	Chennai	D	13.15 (Tue, Thu)	Speed : 48 Kmph
08.10/08.25	A/D	Renigunta	A/D	15.30/15.45	Dist : 713 Kms
01.20/01.25	A/D	Bellary	A/D	22.25/22.30	Speed : 49 Kmph
03.45 (Wed, Fri)	A	Hubballi	A	03.45 (Wed, Fri)	
Train No. 17323 (MAS - UBL) Express	A/D	Station	A/D	Express	

Composition : 2 SLR + 1 ACW + 1 ACN + 6 GSN + 6 GS = 16 Coaches
(Lie-over rake of T. No. 17314/17313 Exp)

Primary Maintenance : UBL with RBPC

Days of Service : Ex. UBL on Mon, Wed & Ex. MAS on Tue, Thu

Traction : Diesel

Rake Requirement : Nil

Commercial Stoppages : SWRly - GDG, KBL, HPT, TNGL, BAY
SCRly - ~~GTL~~, ~~GY~~, ~~TU~~, ~~KDR~~, ~~M00~~, ~~YA~~, ~~HX~~, ~~NRE~~, ~~RTR~~, ~~KBV~~
SRly - ~~PUT~~, ~~TRT~~, ~~ATT~~, ~~PER~~ (up direction)

Discussed and Agreed

CPTM/SWR/UBL

CPTM/SCR/SCR

CPTM/SR/MAS

28/1/16

[Signature]

[Signature]

MINUTES OF IRTTC - 2016 AT CHENNAI
FROM 27.01.2016 TO 29.01.2016

South Western Railway Proposal No. A.5

Introduction of Yesvantpur - Pandrāpur-Yesvantpur Weekly Express.

Abstract Timings :

Train No. 16541 (YPR - PVR) Express	A/D	Station	A/D	Train No. 16542 (PVR - YPR) Express
18.00 (Thu)	D	Yesvantpur	A	06.20 (Sat)
18.58/19.00	A/D	Tumkur	A/D	05.08/05.10
02.50	D	South Hubballi	D	22.30
03.00/03.15	A/D	Hubballi	A/D	22.05/22.20
08.40/09.10	A/D	Miraj	A/D	16.15/16.30
11.35 (Fri)	A	Pandrāpur	D	13.35 (Fri)

Composition : 2 SLR + 1 ACW + 4 ACN + 10 GSN + 1 FACW + 2 GS + 1 WCB (IN LOCKED CONDITION) = 21 COACHES.

Traction : Diesel

Distance : 888 Kms

Speed : 51.20 KMPH

Maintenance : YPR with RBPC

Days of Service : Ex. YPR on Thu & Ex. PVR on Fri

Rake Requirement : Life-over rake of T. No. 22685/22686 (YPR - CDG - YPR) Exp.

Commercial Stoppages : SWRJ - TK, ASK, RRB, DVG, RNR, HVR, UBL, DWR, BGM, GPB & KUD

CRJ - MRJ, KUK, DLGN & SGLA

Remarks : Discussed and Agreed

CPTM/SWK/UBL

29/1/16

CPTM/CR/CSTM

[Handwritten signature and scribbles]

MINUTES OF IRTTC - 2016 AT CHENNAI
FROM 27.01.2016 TO 29.01.2016

South Western Railway Proposal No. D.1

Diversion of Train No. 16591/16592 (UBL - MYS - MYS - UBL) Hampi Express via YPR, YNK, instead of BNC, YNK

Abstract Timings :

T. No. 16591 (UBL - MYS) Hampi Exp	A/D	Station	A/D	T. No. 16592 (MYS - UBL) Hampi Exp
Existing				Existing
Proposed				Revised
05.12/05.14	D	Yelhanka	A	22.48/22.50
-	A/D	Yesvantpur	A/D	22.25/22.30
-	A/D	Malleswaram	A/D	22.12/22.13
05.55/05.57	A/D	Bangalore Cantt.	A/D	-
06.10/06.30	A/D	Bangalore City	A/D	21.55/22.05
				21.40/22.00

There is no change in timings between UBL to YNK and SBC to MYS on either direction.

DRUCC clearance has been taken.

Discussed and Agreed

CPTM/SWR/UBL
22/01/16
Smd

22/1/16

CPTM/SCR/SC

22.1.16
b

MINUTES OF IRTTC - 2016 AT CHENNAI

FROM 27.01.2016 TO 29.01.2016

South Western Railway Proposal No. D.2

Diversion of Train No. 16217/16218 (MYS - SNSI - MYS) Express via YPR, YNK, instead of BNC, YNK

Abstract Timings :

T. No. 16217 (MYS - SNSI) Exp	A/D	Station	A/D	T. No. 16218 (SNSI - MYS) Exp
Existing				Existing
Proposed				Revised
07.55/08.15	D	Bangalore City	A	03.15/03.30
08.25/08.27	A/D	Bangalore Cantt.	A/D	02.55/03.00
-	A/D	Yesvantpur	A/D	-
08.25/08.27	A/D	Yesvantpur	A/D	03.03/03.05
08.58/09.00	A/D	Yelhanka	A/D	02.24/02.25
08.58/09.00	A/D	Yelhanka	A/D	02.24/02.25

There is no change in timings between DM to YNK and SBC to MYS on either direction.

DRUCC clearance has been taken.

Discussed and Agreed

CPTM/SWR/UBL
29/01/16
SM

CPTM/SCR/SC
29/01/16
B

CPTM/CR/CSTM
29/01/2016
M/A

\$29/1/16
DTT/CRS-II/RB

Remarks: feasible, subject to no change in timings over C.R.



MINUTES OF IRTTC - 2016 AT CHENNAI
FROM 27.01.2016 TO 29.01.2016

South Western Railway Proposal No. B.3
(Railway Board Agenda for Increase in Frequency - Sl. No. 12)

Increase in frequency of Train No. 16579/16580 (YPR - SMET - YPR) Bi-weekly
Express to Daily

Abstract Timings :

Train No. 16579 (YPR - SMET) Express	A/D	Station	A/D	Existing		Proposed	
				Existing	Proposed	Daily Service with existing timings	Existing timings
Train No. 16580 (SMET - YPR) Express	A/D	Station	A/D	Existing	Proposed	Daily Service with existing timings	Existing timings
				21.00 (Sat, Sun)	15.30 (Sat, Sun)	D	A
Train No. 16579 (YPR - SMET) Express	A/D	Station	A/D	Existing	Proposed	Daily Service with existing timings	Existing timings
				09.00 (Sat, Sun)	14.45 (Sat, Sun)	D	A
Train No. 16580 (SMET - YPR) Express	A/D	Station	A/D	Existing	Proposed	Daily Service with existing timings	Existing timings
				21.00 (Sat, Sun)	15.30 (Sat, Sun)	A	D
Train No. 16579 (YPR - SMET) Express	A/D	Station	A/D	Existing	Proposed	Daily Service with existing timings	Existing timings
				09.00 (Sat, Sun)	14.45 (Sat, Sun)	D	A

Composition : 2 LWLRM + 12 LGSZ + 1 LCZAC = 15 Coaches

Primary Maintenance : YPR with RBPC

Distance : 268 Kms

Traction : Diesel

Days of Service : Bi-weekly to Daily

Rake Requirement : One rake of above composition to be supplied by Railway Board.

Discussed and Agreed

CPTM/SWR/UBL

Railway Board

(TENTATIVE AND CONFIDENTIAL)

**WESTERN RAILWAY
MINUTES OF IRTC MEETING HELD AT CHENNAI
FROM 27/01/2016 TO 29/01/2016**

**3. NEW TRAIN BETWEEN BANDRA (T) TO GORAKHPUR S.FAST (WEEKLY)
(RB,WCR,NCR,NER,NR)**

Abstract Timings :-

Dn	Station	Up
(D) 05.10 (Sun)	Bandra (T)	(A) 16.15 (Wed)
Pass/16.00	Nagda	Pass/05.10
23.20/23.25	Bharatpur	21.25/21.30
01.25/01.35	Mathura Jn.	19.20/19.30
(Via KSJ-FBD-KJN-CNB)		
08.25/08.35	Kanpur Central	12.05/12.10
10.10/10.20	Lucknow	10.05/10.15
Pass./11.20	Barabanki	Pass./09.06
(A) 15.30 (Mon)	Gorakhpur	(D) 04.45 (Tue)
1957 KMS	Distance	1957 KMS
34'.20"	TOR	35.30"
57.00 KMPH	SPEED	55.13 KMPH

Stoppages proposed:

- (WR) -BVI,VAPI,ST,BRC,DHD,RTM,
- (WCR) -RMGANJ MANDI, KOTA,SWM,GGC,BTE
- (NCR)-AH,MTJ
- (NER)-KLD,BST,GONDA,CPA,KJN,FBD,KSJ,HTC
- (NR)-

Number of rake required: One

Normal composition:

ACCW-1, ACCWN-2, ACCN-3, GSCN-8, WCB-1, GS-6, SLR-1, SLRD-1 = 23 Chs
Primary Maintenance: BDTs
Secondary Maintenance :- GKP

Loco requirement: Electric /Diesel

Remarks :- AGREED (Regular train to be run as "SUIDHA" during summer / winter / Festival season)

CPTM-WR
28/1/16

CPTM-WCR
29.1.16

CPTM-NCR

CPTM-NER
29/1/16

CPTM-NR

DTT/UG-II
28/1/16

WESTERN RAILWAY
MINUTES OF IRTTC MEETING HELD AT CHENNAI
FROM 27/01/2016 TO 29/01/2016

EXTENSION OF SERVICES

1. Extension of 79305/79306, 79307/79308, 79309/79310 RTM - IND DEMU, 79311/79312 RTM - LMNR DEMU (After Gauge conversion from IND to MHOW)

79305	79307	79309	79311	STN		79306	79308	79310	79312
Daily	Daily	Daily	Daily			Daily	Daily	Daily	Daily
06.00	10.50	14.20	19.10	D RTM	A	14.00	18.35	22.00	09.20
08.40	13.20	16.50	21.50	A IND	D	11.20	16.05	19.30	06.40
08.50	13.30	17.00	22.00	D	A	11.10	15.55	19.20	06.30
09.50	14.30	18.00	23.00	A MHOW	D	10.10	14.50	18.20	05.30

Rake required :- One DEMU

Handwritten signature
CPTM-WR
28/1/16

Handwritten initials
28/1/16

WESTERN RAILWAY
MINUTES OF IRTC MEETING HELD AT CHENNAI
FROM 27/01/2016 TO 29/01/2016

9) NEW TRAIN BETWEEN RAJKOT TO PORBANDAR PASSENGER (VIA JLR-WSJ)
 (RB)

Abstract timings :-

DN	STATION	UP
19.15-(D)	RJT	13.15(A)
21.00/21.02	JLR	11.23/11.25
22.41/22.43	WSJ	09.43/09.45
23.35-(A)	PBR	08.50-(D)
4'20" hrs	TOR	4'10"
202 KM	DISTANCE	202 KM
46.62 kmph	Avg. Speed	48.48 kmph

Frequency: Daily

Rake Requirement: one

Composition: 7 GS + 2 SLR = 9 Coaches

Maintenance Pattern : Primary - RJT (RBPC)

Traction: Diesel

Loco Requirement: one.

Commercial Stoppage: BKNQ, RBR, GDL, Gonta, VRR, NUD, JLR, DJI, UA, BHY, PLM, JDH, WAB, WSJ, TSRI, RWO

Rake Link

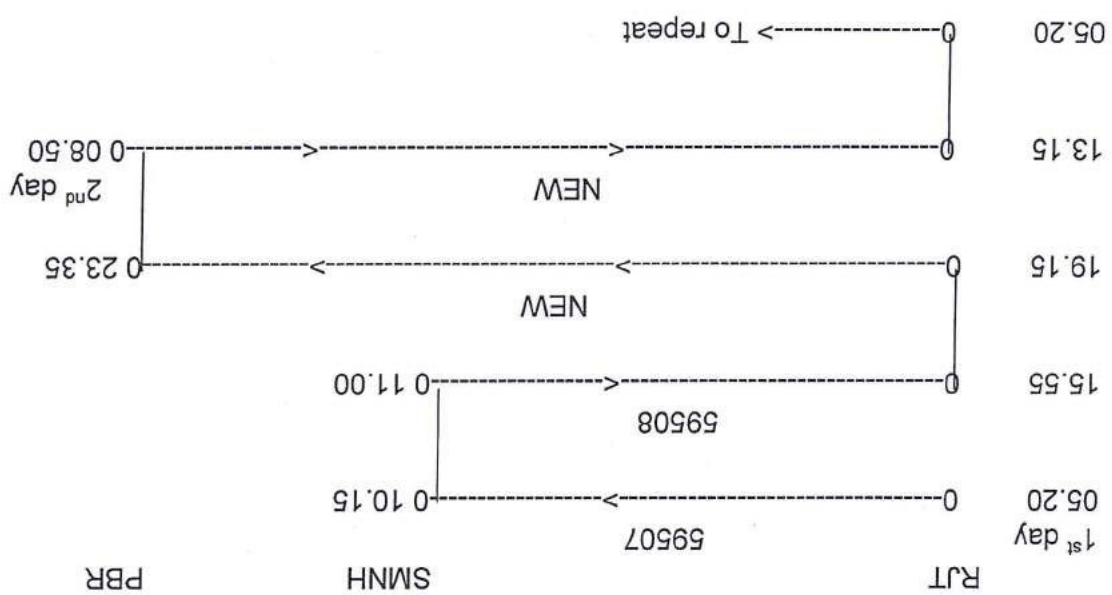

Remarks :- AGREED

CPTM-WR
 20/1/16

20/1/16

(TENTATIVE AND CONFIDENTIAL)

WESTERN RAILWAY
MINUTES OF IRTTC MEETING HELD AT CHENNAI
FROM 27/01/2016 TO 29/01/2016

3. Extension of 19578/19577 TEN - HAPA TO JAM

19577	TEN-HAPA	STN	19578
07.55(Mon/Tu)	TEN	A	22.30(Sun/Mon)
04.55(W/Th)	A HAPA	D	21.20
05.05	D	A	21.18(Fri/Sa)
05.20(W/Th)	A JAM	D	21.05(Fri/Sa)

Rake Required :- Nil

Remarks :- AGREED

CPTM-WR

Handwritten signature
28/1/16

Handwritten signature
29/1/16

WESTERN RAILWAY
MINUTES OF IRTC MEETING HELD AT CHENNAI
FROM 27/01/2016 TO 29/01/2016

2. Extension of 11701/11702 JBP – IND Express and 11703/11704 Rewa – IND to MHOW (After Gauge conversion from IND to MHOW)

11701	11703	STN	11702	11704
JBP-IND	REWA-IND		IND-JBP	IND-REWA
(Mon/Th/Fri)	(W/Sa/Su)		(M/Th/Su)	(Tu/F/Sa)
20.30	21.30	A	04.00	04.00
20.40	21.40	D	03.50	03.50
21.30	22.30	A	03.00	03.00
			MHOW	

Rake Required :- Nil

Remarks :- AGREED

CPTM-WR
28/1/16

CPTM-WCR
28.1.16

28/1/16

(TENTATIVE AND CONFIDENTIAL)

WESTERN RAILWAY

MINUTES OF IRTC MEETING HELD AT CHENNAI

FROM 27/01/2016 TO 29/01/2016

NEW TRAIN BETWEEN IND - PUNE (BI-WEEKLY)

Abstract timings:

Stations			Average Speed	
IND-PUNE			49.01	
			968	
			19.45	
			12.25(Wed/Su)	
	A	PUNE	17.30(Wed/Sun)	D
		TOR	20.00	
		Distance	968	
		Average Speed	48.40	

Stoppages proposed:

(WR) - DWX, UJN, NAD, RTM, MGN, DHD, GDA, BRC, ST, BSR

(CR) - BIRD, KJT, LNL, CCH, PNVL

Number of rake required: One

Normal composition: SLR/D-2, ACCW-1, ACCN-3, GSCN-12, GS-4 = 22 Coaches

Primary Maintenance: IND (RBPC) Terminating :- PUNE

Loco requirement: One

Remarks :- WR - Train will be introduced after construction of new out line

Signature
CPTM-CR

Dr. Ramesh S -

- (i) Train no 51410/51435 arrival/depart. ex Pune at 1625 hrs and 1705 hrs will be terminated at GPR instead of Pune station.
- (ii) Local train 9809 Sd. dep ex LNL at 1000 hrs will be pre-ferred to 1000 hrs
- (iii) Goods train movement between LNL - Pune will be restricted.
- (iv) The lead of the proposed LR - weekly INDB-Pune will have to be restricted to 17 (seventeen) days
- (v) The timings in the direction is subject to revised timings of train no 17318 LIT-UBL which is likely to be effected from April '16.

CPTM-WR

Signature 29/1/16

Signature 29/1/16

(TENTATIVE AND CONFIDENTIAL)

**WESTERN RAILWAY
MINUTES OF IRTC MEETING HELD AT CHENNAI**

FROM 27/01/2016 TO 29/01/2016

(RB,CR,KRCL,SR)

5) NEW TRAIN BETWEEN INDORE - KOCHUVELI S.FAST (WEEKLY)

Abstract timings

DN	Station	UP
Dep. 21.05(Tu)	IND	Arr. 05.15(Sun)
P/03.45(Wed)	GDA	P/22.30
04.40/04.50	BRC	21.15/21.25
07.15/07.25	ST	18.45/18.55
11.20/11.25	BSR	15.10/15.30
15.25/15.30	ROHA	12.15/12.20(Sat)
P/05.40(Thu)	TOK	P/23.00
Arr. 19.10(Thu)	KCVL	Dep. 11.00(Fri)
46.05	TOR	42.15
2310	Distance	2310
50.13	Average Speed	54.67

Distance(Route Kms) :-

IND - BSR(WR) - 782

BSR-ROHA(CR) - 144

ROHA-TOK(KRCL) - 738

TOK-KCVL(SR) - 646

TOTAL - 2310

Frequency Proposed :- Weekly

Stoppages Proposed :-

(WR)DWX, UJN, NAD, RTM, DHD, BRC, ST, Vapi, BOR, BSR,

(CR)-PNVL, ROHA

(KRCL)-CHI, RN, THVM, MAO, KAWR, UD

(SR)-TCR, AWY, ERS, ALLP, QLN, KYJ, SR, CAN, KGG, MAJN

Traction :- Diesel (End to End)

Rake Requirement :- One

Loco Requirement :- One (Diesel)

Composition :- SLR/D-2, GS-4, GSCN-12, ACCN-2 & ACCW-1 = 21 Coaches.

Maintenance :- Primary - INDB, Secondary - KCVL

Remarks :- **AGREED** (Regular train to be run as "SUIDHA" during summer / winter / Festival season)

CPTM-WR

CPTM-CR

CPTM-KRCL

CPTM-SR

(TENTATIVE AND CONFIDENTIAL)

WESTERN RAILWAY

MINUTES OF IRTC MEETING HELD AT CHENNAI

FROM 27/01/2016 TO 29/01/2016

(RB,NWR,NR)

8) NEW TRAIN BETWEEN GANDHIDHAM TO JALANDHAR CITY

Abstract Timings

GIMB-JUC	STATIONS	Mon	D	A	Thu	JUC-GIMB
17.20	Gandhidham					04.50 (Thu)
22.15/22.20	Palampur					23.15/23.20
11.50/11.55	Rewari					10.00/10.05
14.35/15.05	Hissar					06.10/06.35
19.40/19.50	LDH					01.45/01.55
21.00(Tu)	JUC	A			D	00.30(Wed)
1427	DISTANCE					1427
27.40	TOR					28.20
51.57	Speed					50.36

Stoppages proposed: (WR) -BCOB,SIOB,RDHP,BLDI,DISA,PNU

(NWR) - ABR,SOH,FA,RANI,MJ,BER,AII,KSG,JP,GADJ,DO,BKI,AWR,KRH,RE

HNS, BNW,CKD

(NR) - DUI,SAG,SFM,JHL,LDH

Number of rake required: Nil (Lie-over rake of 19453/12993 GIM-PURI-after integration)

Normal composition: SLR/D-2,GS-6, GSCN-8, ACGN-2,ACCW-1 = 19 Chs

Primary Maintenance: GIMB(RBPC) Terminating :-ASR

Loco requirement: One (DSL)

Rake Link

GIMB

PURI

JUC

Fri 22.45 0 16.10 Sun 12993

12994

Wed 12.50 0 19.45 Mon 19453

19454

Wed 20.55 0 19.55 Fri 19454

Mon 06.55 0 09.05 Sat NEW

Mon 17.20 0 21.00 Tue NEW

Thu 04.50 0 00.30 Wed NEW

Fri 22.45 0 To repeat

Remarks :- AGREED

29/1/16

CPTM-WR 29/1/16

CPTM-NWR 29/1/16

CPTM-NR 29/1/16

WESTERN RAILWAY
MINUTES OF IRTC MEETING HELD AT CHENNAI
FROM 27/01/2016 TO 29/01/2016

INCREASE IN FREQUENCY

Increase in frequency of 22903/22904 BDTs - BHUJ AC Express from Tri-Weekly to Four days

S.No	T.No	From - To	Present days	Proposed days
1	22903	BDTS - BHUJ	Wed, Fri, Sun	Wed, Fri, Su, Tu
2	22904	BHUJ - BDTS	Th, Sat, Mon	Th, Sat, Mon, Wed

Composition :- WLRRM-2, WFAC-1, WACCW-4, WACCN-8, WACCEN-1 = 16 Chs.
Rake Requirement :- One EOG rake required

Remarks :- Agreed

Handwritten signature
CPTM-WR
28/1/16

Handwritten signature
29/1/16

29/1/16

29/1/16
CPTM-NR

29/1/16
CPTM-NWR

29/1/16
CPTM-WR

Note :- No change in timings / route
Remarks :- AGREED

Train No	From	Present	Proposed
14311	Ex.BE	Th,F,Su	Tu,Th,Sa
14312	Ex.Bhuj	Tu,Th,Su	Mon,Tu,Th
14321	Ex.BE	M,Tu,W,Sa	M,W,F,Su
14322	Ex.Bhuj	M,W,F,Sa	Su,W,F,Sa

WESTERN RAILWAY
MINUTES OF IRTG MEETING HELD AT CHENNAI
FROM 27/01/2016 TO 29/01/2016
CHANGE IN DAYS OF 14311/14312, 14321/14322 BE-BHUJ EXPRESS

(TENTATIVE AND CONFIDENTIAL)

WESTERN RAILWAY

MINUTES OF IRTC MEETING HELD AT CHENNAI

FROM 27/01/2016 TO 29/01/2016

(RB,CR,KRCL,SR)

7) NEW TRAIN BETWEEN GANDHIDHAM - TIRUNELVELI (Weekly)

Abstract timings

GIMB-TEN	Station	TEN-GIMB
(D) 14.00 (Mon)	Gandhidham	(A) 04.50 (Sat)
03.10/03.15 (Tue)	Vasai Road	15.10/15.15
Pass.../06.20/15	Roha	Pass/12.15(Fri)
Pass.../19.05	Thokur	Pass./23.00
Pass../02.07(W)	SRR(B)	Pass/16.50
11.30 (W)	Tirunelveli(TEN)	(D) 07.55 (Thu)
2421 kms.	Distance	2421 kms.
45'.30"	TOR	44'.55"
53.21 kmph.	Speed	53.89 kmph.

12/15/2015

06/20/25

Distance(Route Kms) :-

GIMB - BSR(WR) - 745

BSR-ROHA(CR) - 144

ROHA-TOK(KRCL)- 738

TOK-TEN(SR) - 794

TOTAL - 2421

Stoppages proposed: (WR) - SIOB,BCOB,DHG,ADI,BRC,ST,VAPI,BOR,BSR

(CR) - PNVL,

(KRCL) - CHI, RN, KADL,KRML,MAO,KAWR,KT,UVD

(SR) - SRR, CLT,CAN,KGO,MAJN,NJT,TVC,DEL,KYJ,ALLP,ERS,TR

Number of rake required: One

Normal composition: SLR/D-2, GS-6, GSCN-8,ACCN-5, ACW-1 = 22 Coaches

Primary Maintenance: GIM

Secondary - TEN

Loco requirement: One(DSL)

Remarks :- AGREED

Handwritten signature and notes:
 CPTM-WR 28-1-16
 CPTM-CR
 CPTM=KRCL
 CSO -
 28/01/16

CPTM-SR

Handwritten notes:
 May be run as special to begin with to assess occupancy, subject to SP's approval.
 29/1/16

(TENTATIVE AND CONFIDENTIAL)

WESTERN RAILWAY

MINUTES OF IRTC MEETING HELD AT CHENNAI

FROM 27/01/2016 TO 29/01/2016

1 NEW TRAIN BETWEEN BCT TO LUN AC S. FAST (WEEKLY) (VIA NSZ-JHS)
 (RB,WCR,NCR,NR,NER)

Abstract timings:

BCT - LUN		Stations	LUN - BCT		63.20
20.35 (Thu)	D	BCT	23.10 (Sat)		
P/03.10 (Fri)		GDA	P/15.50		
P/11.05 (Fri)		NSZ-D	P/08.55		
13.15/13.20		BINA	06.40/06.45		
15.10/15.20		Jhansi	03.40/03.50		
19.05/19.15		CNB	00.15/00.20 (Sat)		
20.35 (Fri)	A	LUN	22.45 (Fri)	D	
24'00"		TOR	24.25"		
1517		Distance	1517		
63.20		Average Speed	62.12		

Stoppages proposed:

(WR) BVI, ST BRC, RTM, UJN, BIH

(WCR) - BINA -

(NCR) -

(NR) -

(NER)

Number of rake required: NIL (L/O of 12227/12228, 12239/12240, 22209/22210 After

Integration

Normal composition: LWLRM-2, WLFAC-1, LWACW-3, LWACN-9, LWCBAC-1 = 16 Chs.

Primary Maintenance: BCT (RBP) Terminating :- LUN

Loco requirement: Electric

Remarks: AGREED (Regular train to be run as "SUIDHA" during summer / winter /

Festival season)

(ii) Increase in frequency in future on some days to not feasible due to
 Consider bulk reduction by 45 mt between BCT - BINA

CPTM-WR *Handwritten signature* 29.1.16
 CPTM-WCR *Handwritten signature* 29.1.16
 CPTM-NCR *Handwritten signature* 29.1.16
 CPTM-NR *Handwritten signature* 29.1.16
 CPTM-NER *Handwritten signature* 29.1.16

Not agreed by NCR & WCR
 as similar works are
 getting informed.

29.1.16
 DTT/ly-II/KB

(TENTATIVE AND CONFIDENTIAL)

WESTERN RAILWAY
 MINUTES OF IRTC MEETING HELD AT CHENNAI
 FROM 27/01/2016 TO 29/01/2016

(RB,WR)

CONVERSION OF 19569/19570 OKHA - BSB EXPRESS TO SUPER FAST

19569 OKHA - BSB	STN	19570 BSB - OKHA
Existing	Revised	Existing
13.45	13.45	09.10
07.17 10/07/12	07.17 10/07/12	15.39 33/35
14.00 ✓	14.00 ✓	09.05 ✓
02.00	23.50	01.10
05.30	02.45	21.55
2041		2041
39.45	37.00	35.15
51.35	55.16	57.90

Remarks :-

CPTM-WR
[Signature] 28/1/16

CPTM-WCR
[Signature] 29.1.16

CPTM-NCR
[Signature]

CPTM-NR
[Signature] 28/1/16

CONFIDENTIAL

WEST CENTRAL RAILWAY

Minutes of meeting held at CHENNAI/SR. HQ from 27TH to 29TH JAN 2016

WCR AGENDA ITEM NO.1.2.1

1.2.1	Extension of 22981/22982 Kota-Sriganganagar to Bhatinda (No rake required)
-------	---

It is agreed to extend the service of 22981/22982 KOTA-SG NR Daily Express to Bhatinda in the existing lie-over at Sriganganagar.

Existing & Proposed Timings:

22981 KOTA-SG NR/BTI		22982 BTI/SG NR-KOTA	
KOTA-SG NR	KOTA-BTI	SG NR-KOTA	BTI-KOTA
D.17.20	D.17.25	A.09.45	A.09.45
19.02-19.20	19.05-19.20	07.45-08.05	07.45-08.05
A.10.00	10.10-10.15	D.17.05	17.05-17.15
--	A.12.25	--	D.14.45
19.00 Hrs.	19.00 Hrs.		19.00 Hrs.
1045 kms	1045 kms		1045 kms
55 kmph	55 kmph		55 kmph

: Nil

Requirement of Rake

: 1 ELECTRIC LOCO. (Train to be operated by electric loco betn KOTA-SWM-KOTA)

CPTM/WCR 29-1-16
CPTM/WCR 29/1/16
CPTM/WCR 29/1/16
CPTM/WCR 29/1/16

TENTATIVE

CONFIDENTIAL

WEST CENTRAL RAILWAY

Minutes of meeting held at CHENNAI/SR. HQ from 27TH to 29TH JAN 2016

WCR AGENDA ITEM NO.1.1.7

1.1.7	Barmer to Jhalawar City Tri-weekly Exp.
-------	---

It is agreed to run a new daily train between Jhalawar city and Barmer on the following timings.

Frequency: Tri-Weekly due to non availability of path.

Ex. BME- WED, FRI, SUN
Ex. JLWC - THU, SAT, MON

Tentative Timings: On the path of 12396 FL-SWM & 12315 SWM-FL

BME-JLWC		JLWC-BME	
Arr.	Dep.	STATION	Arr.
--	16.30	Barmer	04.00
04.50	05.10	SWM	15.00
06.20	06.30	KOTA	13.25
08.45	--	Jhalawar city	--
16.15		TOR	17.00
856		DISTANCE	856
52.6 Kmph		SPEED	50.4 Kmph

Halt over WCR: RMA, DKNT, KOTA, SWM
Halt over NWR: CKB, BNLW, DPA, JP, KJU, JOB, FL, KMNC, MKM, DNA, MTD, GOTN,
JU, LUNI, UTL, BLT, SMR
Composition: 2SLR+4GS+8GSCN+2ACGN+1ACGW = 17 COACHES
(LHB coach maintenance facility is available at BME)
Requirement of rake: One from Rly. Bd. to NWR.
Primary Maintenance: Barmer (RBPC)

CPTM/WCR
28/1/16

CPTM/WCR
28/1/16

CPTM/WCR
28.1.16

CPTM/WCR
28.01.16

MD RB
25/1/16

CPTM/SECR
28/01/16

Coach Requirement: One ACCZ from Rly. Bd.
 Stoppages: As existing
 Primary Maintenance: HBJ (RBPC)

11265 JBP-ABKP	STATION	11266 ABKP-JBP
D. 14.05	Jabalpur	A. 14.55
TH 16.05	NKJ 'C'	TH 12.40
A. 22.40	Ambikapur	D. 06.20

Proposed Timings:

as under:
 It is agreed to increase the frequency from three days to daily by integration of rake link

from 3 days to Daily.
 11265/11266 JBP-ABKP is the only train serving Shahdol-Ambikapur section direct from Jabalpur for High Court and Coal mines Office. It is proposed to increase the frequency

1.3.1	Increase in frequency of 11265/11266 JBP-ABKP Tri-weekly express to Daily by integration of Rake Link (No rake required)
-------	--

WCR AGENDA ITEM NO.1.3.1.

RAILWAY BOARD AGENDA ITEM NO.

Minutes of meeting held at CHENNAI/SR. HQ from 27TH to 29TH JAN 2016

WEST CENTRAL RAILWAY

CONFIDENTIAL

TENTATIVE

TENTATIVE

CONFIDENTIAL

WEST CENTRAL RAILWAY

Minutes of meeting held at CHENNAI/SR. HQ from 27TH to 29TH JAN 2016

WCR AGENDA ITEM NO.1.1.16

1.1.16	BPL-REWA WEEKLY Express utilizing lie-over of 12183/12184 BPL-PBH Exp.
--------	--

It is agreed to run a Weekly superfast train between BPL and REWA on the following day and timings:

Days of service: Ex. Bhopal on Thursday
Ex. REWA on Thursday

Proposed Timings:

BPL-REWA		STATION		REWA-BPL	
ARR.	DEP.			ARR.	DEP.
THU	10.00	BHOPAL		09.25	FRI
11.50	12.05	ITARSI		06.00	06.20
15.45	15.55	JABALPUR		01.40	01.50
18.25	18.35	SATNA		22.35	22.40
19.50		REWA		THU	21.15

Proposed stoppages: HBJ, HBD, ET, PPI, NU, JBP, KTE, MYR, STA
Composition: 2SLR/D+4GS+10GSCN+1ACCW+3ACCN = 20 Coach
Rate : lie over Rake of 12183/12184 Exp.
Primary Maintenance: BPL (RBPC)

5/2/16
/RS

[Signature]
29.1.16
CPTM/WCR

CONFIDENTIAL

TENTATIVE

WEST CENTRAL RAILWAY

Minutes of meeting held at CHENNAI/SR. HQ from 27TH to 29TH JAN 2016

WCR AGENDA ITEM NO.1.2.3

1.2.3	Extension of 59833/59834 KOTA-NMH passenger to Mandasaur
-------	--

59833 Kota-NMH Passenger trains reaching NMH at 05.55 hrs and 59834 departure NMH at 22.30 hrs, in between the rake is utilised to run 59835/59836 NMH-UDZ Passenger, with little changes in existing timings 59833/59834 Kota-NMH Passenger can be extended to MDS if agreed by WR. This will be benefited to travelling public.

Existing & Proposed timings:

Station	Existing		Proposed		Station	Existing		Proposed	
	Arri	Dep	Arri	Dep		Arri	Dep	Arri	Dep
59833					59833				
KOTA	22.45			21.25	MDS	--	--		21.00
CNA	03.55	03.57	02.00	02.02	NMH	--	--	22.30	22.25
NMH	05.55	--	04.00	04.05	CNA	00.48	00.50	00.48	00.50
MDS	--	--	05.20	--	KOTA	05.00	--	05.00	--

Note: Since train no. 59833 KOTA-NMH has been extended up to MDS, therefore 59835/59836 NMH-UDZ has to be extended up to MDS on the timing mention below.

Station	Existing		Proposed		Station	Existing		Proposed	
	Arri	Dep	Arri	Dep		Arri	Dep	Arri	Dep
59835					59835				
MDS	--	--	05.50	--	UDZ	--	14.55	--	14.55
NMH	--	07.00	6.55	07.00	BEC	TH	17.55	TH	17.40
BEC	TH	08.55	TH	08.55	NMH	20.05	--	19.10	19.15
UDZ	11.45	--	11.45	--	MDS	--	20.25	--	20.25

Requirement of Rake : Nil

Primary Maintenance : Kota as existing

CPTM/WR 29/1/16
[Signature]

CPTM/WR
28.1.16
[Signature]

29/1/16
[Signature]

CPTM/WCR
29.1.16
[Signature]

TENTATIVE

CONFIDENTIAL

WEST CENTRAL RAILWAY

Minutes of meeting held at CHENNAI/SR. HQ from 27TH to 29TH JAN 2016

WCR AGENDA ITEM NO.1.1.8

1.1.8	Kota to Jhalawar city (Regularization of special train by utilizing lie-over rake of 51612/ 51611 Kota-Bina passenger)
-------	--

05612/05611 Kota-Jhalawar city-Kota daily special passenger is being run since 04.03.2015 to date by utilizing lieover rake of 51612/ 51611 Kota-Bina passenger. Now, it is decided to regularize the service on the following timings:

Proposed Timings:

Kota-Jhalawar City		STATION	Jhalawar City-Kota	
Arr.	Dep.		Arr.	Dep.
--	19.10	KOTA	08.05	--
20.40	20.45	RMA	06.35	06.40
21.30	--	JLWC	--	06.00

Proposed stoppages: All stations between Kota and JLWC
Composition : 2SLR/D+8GS = 10 Coaches (Lie-over)
Primary : Existing Bina (RBPC)

28.01.16
CPTM/WCR

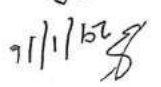
29/1/16
ND RB

CONFIDENTIAL

TENTATIVE

WEST CENTRAL RAILWAY

Minutes of meeting held at CHENNAI/SR. HQ from 27TH to 29TH JAN 2016

WCR IRTTC AGENDA ITEM NO.1.1.94.

1.1.94	Jabalpur to Atari via Amritsar Bi-Weekly Super fast Exp.
--------	--

It is agreed to run a biweekly superfast train between Jabalpur and Atari on the following days and timings:

Days of service: Ex. JBP on WED & SAT
Ex. ATARI on THU & SUN

Proposed Timings:

Jabalpur-Atari		Distance from JBP	Station	Atari-Jabalpur	
Arr.	Dep.			Arr.	Dep.
(Wed & Sat)	10.40	0	Jabalpur	15.45	(Fri & Mon)
11.50	12.05	91	Katni	14.10	14.25
TH	16.20	358	Agasod	TH	09.50
TH	22.55	855	Palwal	TH	03.20
00.20	00.50	913	New Delhi	01.30	02.00
07.45	07.55	1225	Ludhiana	18.00	18.10
10.45	10.55	1360	Amritsar	15.40	15.50
11.45	(Thu & Sun)	1386	Atari	(Thu & Sun)	14.45
25.05 Hrs.			TOR	25.00 Hrs.	
55.25 kmph			Speed	55.44 kmph	

Proposed stoppage over WCR: Katni, Damoh, Saugar, Malkhed.

Proposed stoppage over NCR:

Proposed stoppage over NR: ~~Patna~~ NDLS - Pat - Kcde - Umb - RPT - LDH - Pan - Svc - BHM - ASR
Composition: 2SLR/D+4GS+9GGSCN+3ACCN+2ACCW+1WCB = 21 Coaches.
Primary maintenance: JBP (RBPC)

CPTM/NR

Timings not possible over NCR as line capacity constraint & new route path over NCR.
CPTM/NCR

29.1.16
CPTM/WCR

29/1/16

CONFIDENTIAL

WEST CENTRAL RAILWAY

Minutes of meeting held at CHENNAI/SR, HQ from 27th to 29th JAN 2016

RAILWAY BOARD AGENDA ITEM NO.14

WCR AGENDA ITEM NO.1.1.2

1.1.2	Jabalpur to Pune Weekly SUIDHA Super fast via MMR
-------	---

It is agreed to run a weekly SUIDHA superfast train between Jabalpur and Pune on the following days and timings:

Days of service: ex. JBP on MON

ex. PUNE on TUE

Proposed Timings:

JBP-PUNE		STATION	PUNE-JBP	
Arr.	Dep.		Arr.	Dep.
MON	09.00	JBP	03.30	WED
12.55	13.15	ET	23.00	23.15
TH	15.55	KNW	TH	20.35
19.50	20.00	MMR	15.20	15.30
02.15	02.40	DD	10.20	11.05
04.00	TUE	PUNE	TUE	08.45
19'00"		TOR	18'45"	
1049		Distance	1049	
55.2 kmph		SPEED	56.8 kmph	

Stoppages over WCR: Narsinghpur, Pipariya, Itarsi,
Stoppages over CR: Bhusaval, Manmad, Kopargaon, Ahmednagar
Composition : 2SLR/D+9SSGN+2ACCW+3ACCN = 16 Coaches
Rake Requirement: One rake from Railway Board.
Primary Maintenance: JBP (RBPC)

CPTM/CR

CPTM/CR will
revert back
after visiting
Pune station
and send his
remarks.

29/1/16
DT/LL-JT

CPTM/WCR
29.1.16

CPTM/CR

CPTM/WCR

DT/CR-II
29/1/16

CPTM/CR will
revert back after
noting Pune
Station and send
his remarks.

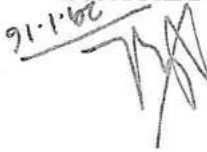
29.1.16

Stoppages over WCR: Itarsi
Stoppages over CR: Bhusaval, Manmad, Kopargaon, Ahmednagar
Composition : 2SLR/D+9GSCN+2ACCW+3ACCN = 16 Coaches
Requirement of rake : One rake from Rly. Bd.
Primary Maintenance : HBJ (RBPC)

HBJ-PUNE		PUNE-HBJ	
Arr.	Dep.	STATION	Arr.
Sat	16.50	Habiganj	05.30
21.00	21.05	Khandwa	01.00
08.05	Sun	Pune	Sun
888 km		888 km	
15.15 Hrs. = 915 mts		15.15 Hrs. = 915 mts	
58.23 kmph		58.23 kmph	
SPEED		SPEED	

Proposed Timings:

Days of service: Ex. HBJ on Sat
Ex. PUNE on Sun

It is agreed to run a weekly SVIDHA Super fast superfast train between Habiganj to Pune on the following days and timings:

1.1.3	Habiganj to Pune Weekly SVIDHA Super fast via MMR
-------	---

WCR IRTTC AGENDA ITEM NO.1.1.3.

Minutes of meeting held at CHENNAI/SR. HQ from 27TH to 29^H JAN 2016

WEST CENTRAL RAILWAY

TENTATIVE

CONFIDENTIAL

CPTM/NWR

CPTM/WR

CPTM/WCR

Agreed with no change
over WF system.
29/1/16

28.1.16
[Signature]

Proposed halts over WCR. : NO CHANGE
Proposed stoppage on extended portion of NWR: JOB,FL, RKB, GOTN, MTD, REN,
DNA, MKN, KMNC, NAC
Requirement of Rake : One rake of 10 Coaches for 59805/59806 JP-BXN to
NWR with primary maintenance at NWR.
Coach requirement for augmentation of 59801/59802:
1GS+3GSCN+1ACN +1ACGW X 3 Rakes.
Distance : - 554 (KOTA- BGT) + 266(KOTA-RTM) = 820 X 2 = 1640 KM
Primary Maintenance : Kota as existing
Composition after augmentation: 2SLR/D+4GS+8CN+2ACCN+1CWNAC+1ACGW=18

Station	Proposed Express		Existing		Arr	Dep
	Arr	Dep	Arr	Dep		
KOTA	23.50	--	05.35	--	05.35	--
	01.45	02.05	02.45	03.05	02.45	03.05
SWM	04.35	04.45	--	23.55	23.55	00.05
	04.35	04.45	05.57	--	05.57	00.05
JP	04.35	04.45	--	23.55	23.55	00.05
	04.35	04.45	05.57	--	05.57	00.05
FL	04.35	04.45	--	23.55	23.55	00.05
	04.35	04.45	11.45	--	11.45	18.00
BGT	04.35	04.45	11.45	--	11.45	18.00
	04.35	04.45	11.45	--	11.45	18.00
TOR	04.45 Hrs	11.55 Hrs	05.40 Hrs	11.35 Hrs	05.40 Hrs	11.35 Hrs
	04.45 Hrs	11.55 Hrs	05.40 Hrs	11.35 Hrs	05.40 Hrs	11.35 Hrs
Distance	240 kms	554 kms	240 kms	554 kms	240 kms	554 kms
	240 kms	554 kms	240 kms	554 kms	240 kms	554 kms
Speed	46.48, 14 kmph	46.48, 14 kmph	42.4 kmph	47.82 kmph	42.4 kmph	47.82 kmph
	46.48, 14 kmph	46.48, 14 kmph	42.4 kmph	47.82 kmph	42.4 kmph	47.82 kmph

Tentative Timings:

It is agreed to extend 59801/59802 KOTA-JP-RTM passenger to Bhagat Ki Kothi for better utilization of stock and increase earnings. It is also agreed to integrate running of FL-BXN-FL passenger with extension to Ajmer. One extra rake of 2SLR/D+8GS coaches coach will be required.

Extension of 59801/59802 KOTA-JP-RTM to BGT by converting into Express service between Kota and BGT

fast passenger

WCR IRTTC AGENDA ITEM NO.1.2.2

Minutes of meeting held at CHENNAI/SR. HQ from 27th to 29th JAN 2016

WEST CENTRAL RAILWAY

CONFIDENTIAL

TENTATIVE

CONFIDENTIAL

WEST CENTRAL RAILWAY

Minutes of meeting held at CHENNAI/SR. HQ from 27TH to 29TH JAN 2016

WCR AGENDA ITEM NO.1.1.20/96

1.1.20/96	Jabalpur - Santragachi Via BSP Weekly Superfast Express
-----------	---

It is agreed to run a Bi-Weekly Express train between JBP and SRC on the following day and timings:

Days of service: Ex. JBP on WED
Ex. SRC on THU

Proposed Timings:

Jabalpur-Santragachi		Distance	STATION	Santragachi-Jabalpur	
Arr.	Dep.			Arr.	Dep.
--	20.55	0	Jabalpur	15.10	--
TH	22.35	90	NKJ'C	13.50	TH
04.30	04.45	410	Bilaspur	07.35	07.50
08.10	08.15	615	Jharsuguda	04.20	04.25
17.00	--	1129	Santragachi	--	20.30
20.05 HRS.			TOR	18.40HRS.	
56.21KMPH			SPEED	60.40 KMPH	

Composition: 2SLR+6GS+8GSCN+2ACGN+1ACGW = 19 Coaches

Requirement of rake: One from Rly.Bd.
Primary Maintenance: JBP (RBPC)

CPTM/SER

CPTM/SECR

CPTM/WCR

29/1/16
D-1/TH/4-II

29/1/16

TENTATIVE

CONFIDENTIAL

WEST CENTRAL RAILWAY

Minutes of meeting held at CHENNAI/SR. HQ from 27th to 29th JAN 2016

WCR AGENDA ITEM NO.1.1.5/97

1.1.5/97 | REWA-LOKMANYA TILAK (T) WEEKLY EXPRESS

It is agreed to run a Weekly superfast train between Rewa and Lokmanya Tilak (T) on the following day and timings:

Days of service: Ex. REWA on WED

Ex. LTT on THU

Tentative Timings:

REWA-LTT		LTT-REWA	
ARR.	DEP.	ARR.	DEP.
22.50	14.30	14.40	FRI
03.15	03.20	05.00	05.10
10.45	10.55	02.30	02.35
13.35	THU	19.45	20.15
23.05	23.05	22.00	16.40
1219 KM	1219 KM	1219 KM	55.04 KMPH
52.8 KMPH	SPEED	55.04 KMPH	

Stoppage: over WCR STA, MYR, KTE, JBP, NU, PPI, ET
over CR KMW, BSL, JL, MMR, NK, IGP, KYN

Composition : 2SLR+4GS+10GSCN+4ACCN+2ACGW = 22 Coaches
Requirement of rake : One Rake from Railway Board.
Primary Maintenance : REWA (RBPC)

CPTM/CR

CPTM/WCR
29/1/16
29/1/16

29/1/16
29/1/16

CONFIDENTIAL

WEST CENTRAL RAILWAY

Minutes of meeting held at CHENNAI/SR. HQ from 27TH to 29^H JAN 2016

WCR AGENDA ITEM NO.1.1.4/95

1.1.4/95	Jabalpur to Bandra (T) Weekly Super fast via BPL
----------	--

It is agreed to run a Weekly superfast train between Jabalpur and Bandra (T) on the following day and timings:

Days of service: ex. JBP on THU

ex. BDTs on FRI

Tentative Timings:

JBP-BDTS		STATION	BDTS-JBP	
Arr.	Dep.		Arr.	Dep.
THU	14.20	Jabalpur	18.55	SAT
15.38	15.40	Narsinghpur	16.38	16.40
16.38	16.40	Pipariya	15.18	15.20
18.10	18.30	Itarsi	14.05	14.20
18.48	18.50	Hoshangabad	13.38	13.40
19.58	20.03	Habibganj	11.47	11.58
20.15	20.35	Bhopal	11.25	11.35
23.00	23.05	Ujjain	07.55	08.00
00.35	00.45	Ratlam	06.15	06.25
05.05	05.10	Vadodara	02.40	02.45
06.50	06.55	Surat	00.47	00.49
08.13	08.15	Vapi	22.48	22.50
10.25	10.27	Borivali	21.15	21.17
11.15	FRI	Bandra (T)	FRI	20.30

Composition: 2SLR/D+10GSCN+3ACCN+1ACCW = 16 Coaches

Primary Maintenance: JBP (RBPC)

Traction: Diesel: JBP-ET-JBP Electric: ET-BDTS-ET
Crew and Guard Working: W.Rly: BPL-BDTS-BPL

CPTM/WR

- Already running on
a special on special
fairs on the days
given above.

29/1/16

CPTM/WCR
29.1.16

TENTATIVE



IRITC-2016



Railway: SER
Minutes of the IRTTC meeting held at Chennai from 27-01-2016 To 29-01-2016
Proposal ID - SER15160011
Proposal Type - NEW TRAIN SERVICE
Tentative Proposal

Confidential

Timings

TRAIN No/ PROPOSAL	ARRIVAL	DEPARTURE	STATIONS	ARRIVAL	DEPARTURE	TRAIN No/ PROPOSAL
SER1516001101	05:47:00	05:48:00	RKSN	10:11:00	10:12:00	
	05:00:00	05:00:00	TATA	11:30:00		SER1516001102
	06:56:00	06:57:00	DPS	08:58:00	08:59:00	
	08:00:00		BBN		08:15:00	

Stoppages

ZONE	Commercial	OPERATING
SER	ADTP, GMH, BRBS, SINI, MMV, RKSN, PRSL, CBSA, SIPA, JNK, TABU, KNPS, MLKA, DPS, PDPH, NOMD, BJMD	

Both
 Main
 Reverse

Day Of Operating UP/DN	Distance	Total time of run UP/DN	Average speed UP/DN	Add Reversals	Repercussion	Primary Maintenance	Secondary Maintenance	Loco Requirement	Loco Requirement from Board	Rake Requirement	Rake Requirement from Board	Composition in case of new service	Likely date of Introduction	Remarks:
M,T,W,T,F,S,S	148	03:00:00 / 03:15:00	49 / 46		Path of 3 Goods Trains on each will be lost.	TPKR/KGP	Nil	Nil	Nil	One MEMU-Rake Nil One MEMU-Rake Nil to be integrated with new ROU-TATA MEMU proposed service.	One MEMU-Rake Nil		01/07/2016	To be integrated with proposed TATA-ROU MEMU.

CPTM/SER
 RB
 28/1/16
 28/1/16

Minutes of IRTTC Meeting held at Chennai from 27th to 29th Jan-2016

Item no: B(!!!) & C(!!!) SECR Agenda

Sub: Extension of 68740 / 68739 (Bilaspur-Pendra Road) up to Anuppur & Increase in Frequency of 68749/68750 (Anuppur-Ambikapur) MEMU from 6-days in a week to Daily

It has been decided to extend 68740 / 68739 (Bilaspur-Pendra Road-Bilaspur) MEMU from Pendra Road to Anuppur and Increase in the frequency of 68749/68750 (Anuppur-Ambikapur-Anuppur) MEMU from 6-days in a week to Daily in integrated rake link as given below:-

(A) Extension:

Tentative Timings

68740 (BSP-PND) MEMU to APR	Existing	Proposed	KMS	Station	68739 (PND-BSP) MEMU Ex APR	
					Existing	Proposed
	d.07:30	d.06:00	0	Bilaspur Jn.	a.13:55	a.13:50
	a.10:25	08:50/08:55	101	Pendra Road	d.11:15	11:05 /11:10
	a.09:30	a.09:30	151	Anuppur Jn.		d.10:20

Stoppages : All stations on extended portion

Frequency of Service : Daily

Composition : Existing composition (MC-2, TC-6).

No of rakes required : No extra Rake.

Primary Maintenance : Bhilai (RBPc)

(B) Increase in frequency

Train No.	Existing days	Proposed days
68749 (Anuppur-Ambikapur)	Except Sat	Daily
68750 (Ambikapur-Anuppur)	Except Sat	Daily

Stoppages : As existing.

Frequency of Service : From 6-days to Daily

Composition : Existing composition (MC-2, TC-6).

No of rakes required : No extra Rake

Primary Maintenance : Bhilai

Remarks : Both extension of Bilaspur-Pendra Road to Anuppur and increase in frequency of 68749/68750 (APR-ABKP) from 6 days to daily being integrated rake link and with change of timings as below:

68740(BSP-PND) MEMU up to APR		68739 (PND-BSP) MEMU ex APR	
Existing	Station	Proposed	Station
d.07.30	BSP	d.06.00	APR
a.10.25	PND	08.50/08.55	PND
-	APR	a.09.30	BSP
68747 (BSP-KTE) MEMU		68748 (KTE-BSP) MEMU	
Existing	Station	Proposed	Station
d.06.00	BSP	d.07.00	Existing
08.05/08.07	PND	08.56/08.58	Existing
09.15/09.45	APR	09.57/10.07	Existing
10.45/10.50	SDL	11.00/11.05	Existing
a.14.30	KTE	a.14.30	Existing
68740(BSP-PND) MEMU up to APR		68739 (PND-BSP) MEMU ex APR	
Existing	Station	Proposed	Station
d.07.30	BSP	d.06.00	APR
a.10.25	PND	08.50/08.55	PND
-	APR	a.09.30	BSP
68747 (BSP-KTE) MEMU		68748 (KTE-BSP) MEMU	
Existing	Station	Proposed	Station
d.06.00	BSP	d.07.00	Existing
08.05/08.07	PND	08.56/08.58	Existing
09.15/09.45	APR	09.57/10.07	Existing
10.45/10.50	SDL	11.00/11.05	Existing
a.14.30	KTE	a.14.30	Existing
68740(BSP-PND) MEMU up to APR		68739 (PND-BSP) MEMU ex APR	
Existing	Station	Proposed	Station
d.07.30	BSP	d.06.00	APR
a.10.25	PND	08.50/08.55	PND
-	APR	a.09.30	BSP
68747 (BSP-KTE) MEMU		68748 (KTE-BSP) MEMU	
Existing	Station	Proposed	Station
d.06.00	BSP	d.07.00	Existing
08.05/08.07	PND	08.56/08.58	Existing
09.15/09.45	APR	09.57/10.07	Existing
10.45/10.50	SDL	11.00/11.05	Existing
a.14.30	KTE	a.14.30	Existing
68740(BSP-PND) MEMU up to APR		68739 (PND-BSP) MEMU ex APR	
Existing	Station	Proposed	Station
d.07.30	BSP	d.06.00	APR
a.10.25	PND	08.50/08.55	PND
-	APR	a.09.30	BSP
68747 (BSP-KTE) MEMU		68748 (KTE-BSP) MEMU	
Existing	Station	Proposed	Station
d.06.00	BSP	d.07.00	Existing
08.05/08.07	PND	08.56/08.58	Existing
09.15/09.45	APR	09.57/10.07	Existing
10.45/10.50	SDL	11.00/11.05	Existing
a.14.30	KTE	a.14.30	Existing

SFCR/BSP
CPTM
22/1/16

22/1/16

Existing MEMU RAKE LINK 2015-16

Daily AB

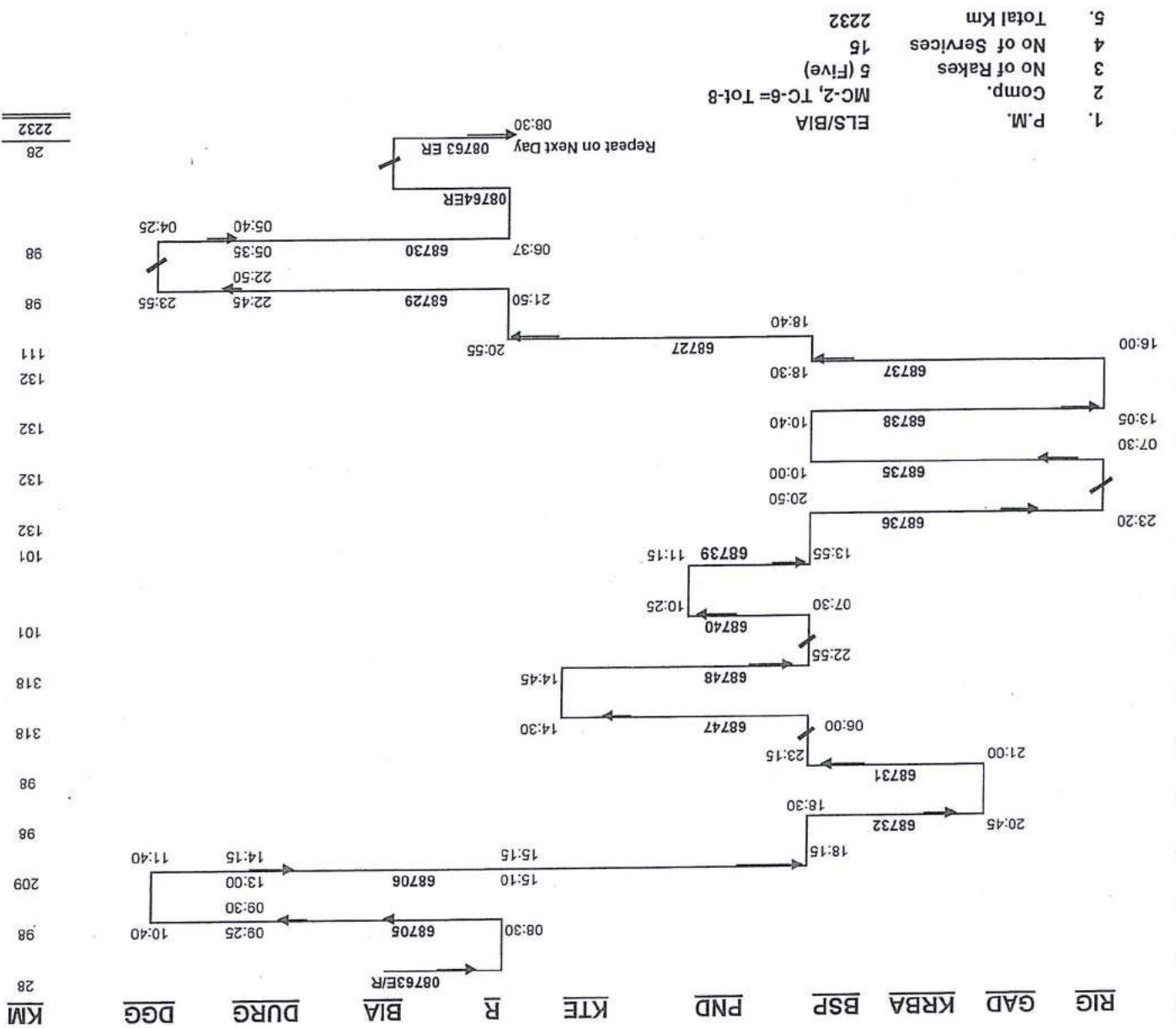

1) Round Trip Distance,

: 2656 KM

2) End to End Distance,

SL	Train no	Distance	Run Time	Avg. Speed	Round Trip Hours
1	68749	175	04:40	37.50	153.00
2	68750	175	04:40	37.50	

3) Normal Composition & Marshalling Order

: MC-3, TC-9= 12 Coaches
(Presently Running with 8 Coaches)

4) Rake Link

: Refer Next Page

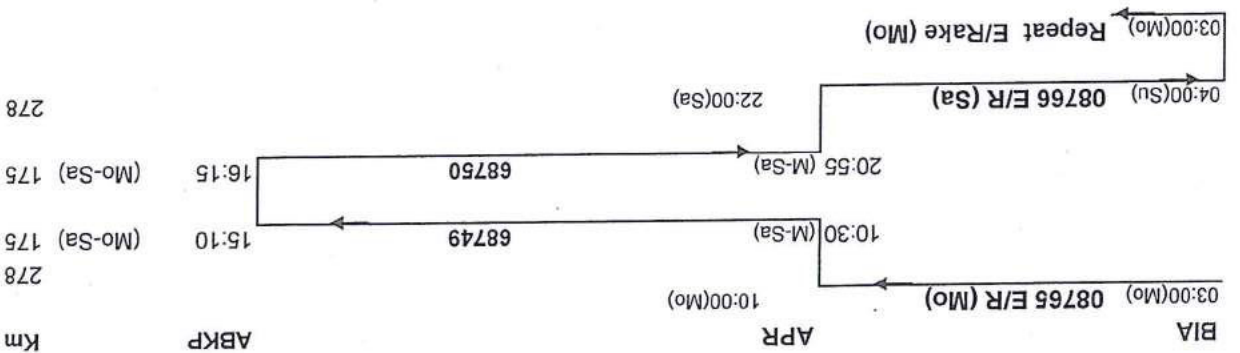

P.N.: There is no service of 68749/68750 on Sunday between APR-ABKP-APR

5) Total Rakes & Owning Rly

: 1 (One) -- S.E.C. Rly

6) Maintenance

: PM --- ELS/BIA

7) Lie Over (in Hrs)

: Primary End BIA 23:00
Secondary End ABKP 01:05
APR- 13:35

Proposed MEMU RAKE LINK 2015-16 on extension of 68740/68739(BSP-PND-BSP) to APR and Increase in Frequency of 68749/68750(APR-ABKP)

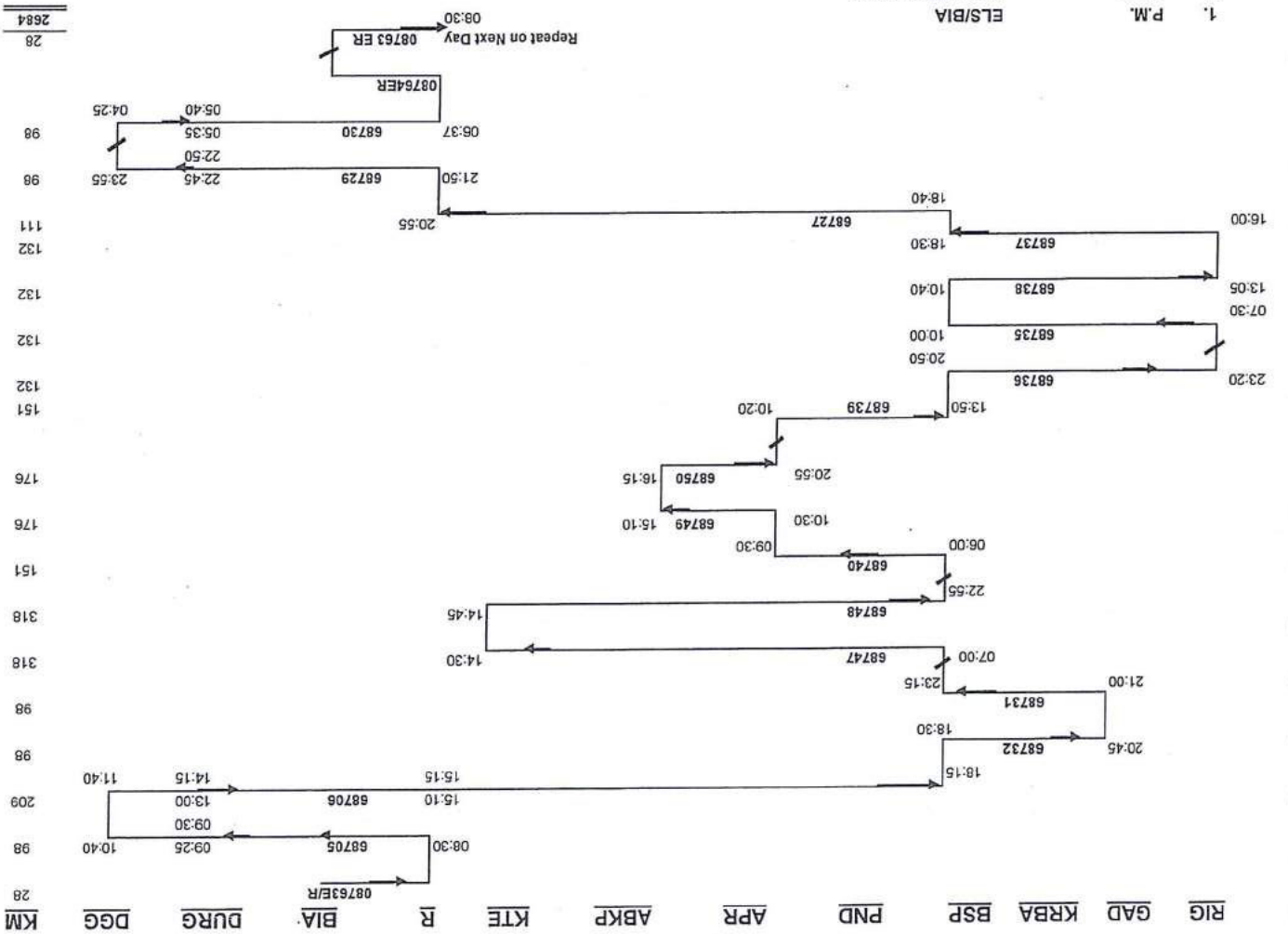

1. P.M. ELS/BIA
 2. Comp. MC-2, TC-6= Tot-8
 3. No of Rakes 6 (Six)
 4. No of Services 17
 5. Total Km 2684

28
 2684

Minutes of IRTTC Meeting held at Chennai from 27th to 29th Jan-2016

Item no: B(!!!) & C(!!!) SECR Agenda

Sub: Extension of 68740 / 68739 (Bilaspur-Pendra Road) up to Anuppur & Increase in Frequency of 68749/68750 (Anuppur-Ambikapur) MEMU from 6-days in a week to Daily

It has been decided to extend 68740 / 68739 (Bilaspur-Pendra Road-Bilaspur) MEMU from Pendra Road to Anuppur and Increase in the frequency of 68749/68750 (Anuppur-Ambikapur-Anuppur) MEMU from 6-days in a week to Daily in integrated rake link as given below:-

(A) Extension:

68740 (BSP-PND) MEMU to APR		68739 (PND-BSP) MEMU Ex APR	
Existing	Proposed	Existing	Proposed
d.07:30	d.06:00	Bilaspur Jn.	Bilaspur Jn.
a.10:25	08:50/08:55	Pendra Road	Pendra Road
	a.09:30	151	Anuppur Jn.

Tentative Timings

Stoppages : All stations on extended portion
 Frequency of Service : Daily
 Composition : Existing composition (MC-2, TC-6)
 No of rakes required : No extra Rake.
 Primary Maintenance : Bhilai (RBPC)

(B) Increase in frequency

Train No.	Existing days	Proposed days
68749 (Anuppur-Ambikapur)	Except Sat	Daily
68750 (Ambikapur-Anuppur)	Except Sat	Daily

Stoppages : As existing.
 Frequency of Service : From 6-days to Daily
 Composition : Existing composition (MC-2, TC-6).
 No of rakes required : No extra Rake
 Primary Maintenance : Bhilai
 Remarks : Both extension of Bilaspur-Pendra Road to Anuppur and increase in frequency of 68749/68750 (APR-ABKP) from 6 days to daily being integrated rake link and with change of timings as below:

68740(BSP-PND) MEMU up to APR		68739 (PND-BSP) MEMU ex APR	
Existing	Proposed	Existing	Proposed
Station	Station	Station	Station
BSP	BSP	KTE	KTE
d.06.00	d.07.00	d.14.45	d.14.45
08.05/08.07	08.56/08.58	17.31/17.36	17.31/17.36
09.15/09.45	09.57/10.07	18.25/18.55	18.25/18.55
10.45/10.50	11.00/11.05	19.45/19.47	19.45/19.47
a.14.30	a.14.30	a.22.55	a.22.55

SECR/BSP
 CPTM
 22/1/16

28/1/16

Existing MEMU RAKE LINK 2015-16

Daily AB

28
2232

RIG GAD KRBA BSP PND KTE R BIA DURG DGG KM

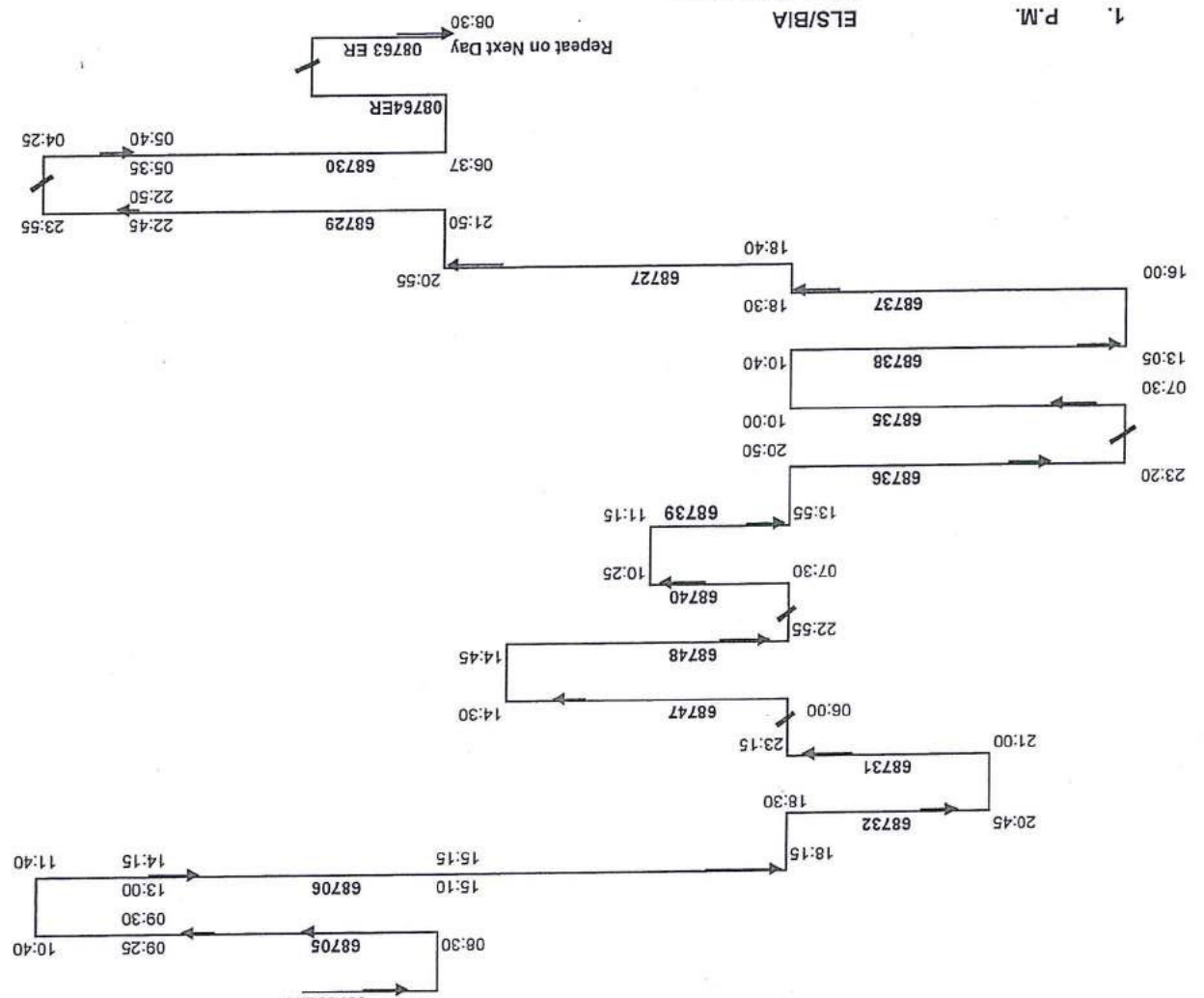

1. P.M. ELS/BIA MC-2, TC-6= Tot-8
2. Comp. 5 (Five)
3. No of Rakes 15
4. No of Services 2232
5. Total Km

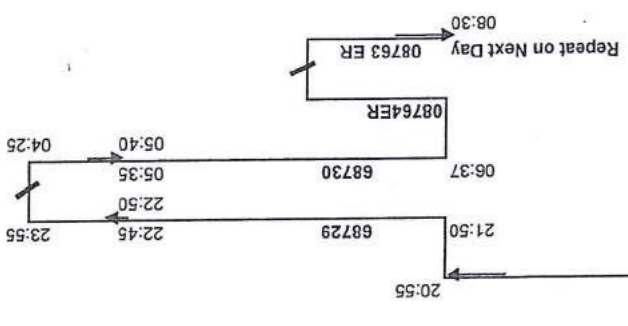

28
2232

1) Round Trip Distance, 2656 KM

SL	Train no	Distance	Run Time	Avg. Speed	Round Trip Hours
1	68749	175	04:40	37.50	153.00
2	68750	175	04:40	37.50	

2) End to End Distance, Run-Time, Avg. Speed

3) Normal Composition & Marshalling Order

MC-3, TC-9= 12 Coaches
(Presently Running with 8 Coaches)

4) Rake Link

: Refer Next Page

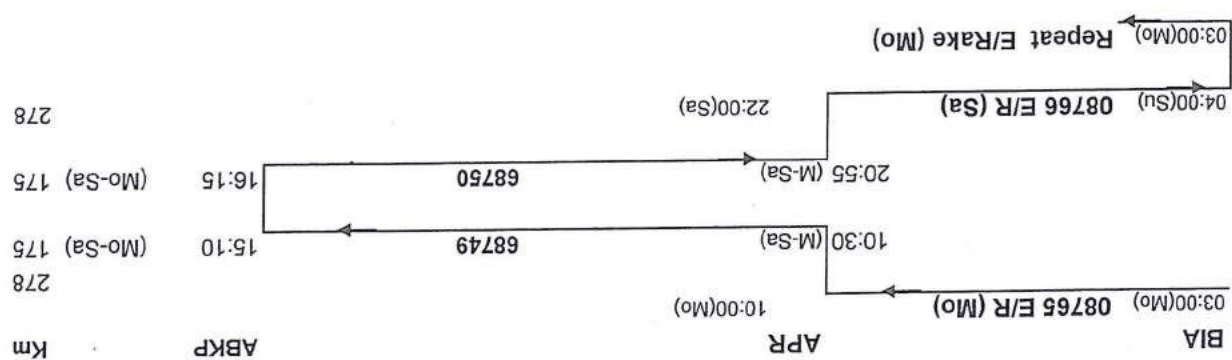

P.M.: There is no service of 68749/68750 on Sunday between APR-ABKP-APR

5) Total Rakes & Owning Rly

: 1 (One) -- S.E.C. Rly

6) Maintenance

: PM --- ELS/BIA

7) Lie Over (in Hrs)

: Primary End BIA 23:00
Secondary End ABKP 01:05
APR- 13:35

Item no: Railway Board's Agenda

Sub: Extension of 18242/18241(Ambikapur-Durg-Ambikapur) Express from Durg to

Gondia

Extension of 18242/18241(Ambikapur-Durg-Ambikapur) Express from Durg to Gondia is not feasible due to following reasons:-

Tentative Timings on extension

18242 (Ambikapur-Durg) To Gondia	Existing		KMS	Station	Ex. Gondia	
	Existing	Proposed			Existing	Proposed
	d.21:15	d.21:15	0	Ambikapur	a.08:10	a.08:10
	a.09:10	09:05/09:15	269	Durg	d.20:50	20:30/20:45
	a.11:30		404	Gondia		d.18:00

- : Stopages
- : Frequency of Service
- : Composition
- : No of rakes required
- : Primary Maintenance
- : Traction
- : Remark

1. With existing lie-over, the extension is not feasible due to only 11.40 hrs lie-over at Durg and the distance between Durg-Gondia- Durg is 270 Km with run time 04.45 hrs.
2. With this rake 58702/58701(Ambikapur-Shadol-Ambikapur) Passenger trains are running as commuter between Ambikapur – Bijuri in both directions. Stabling line constraint at Gondia to hold the rake with one additional rake from Board.
3. Stabling line constraint at Gondia to hold the rake with one additional rake from Board.

Approval of DRCC/2RUC may be obtained, if found feasible at a later date as it may cause rescheduling of Durg (Chattisgarh) to Gondia (Maharashtra).

28/1/16

Integrated Rake Link of 18241 / 18242 (DURG-ABKP-DURG) Express-Cum - Passenger, 58702/58701 (ABKP-SDL-ABKP) Passenger

Daily AB

Link - PE-14

1) Round Trip Distance : 1370 KM

SL	Train No.	Distance	Run Time	Avg. Speed	Round Trip Hours
1	18241	469	11:20	41.38	36:20
2	18242	469	11:55	39.36	
3	58702	216	05:20	40.50	
4	58701	216	05:30	39.27	

2) End to End Distance, Run-Time & Avg. Speed :

21 = GSLR-1 GS-1 WGSCN-1(DURG-CHRM Slip Coach) GSLRD-1 GS-3 WGSCN-6 WGACCN-3 WGACCW-1 GS-3 GSLR-1 (18241/18242)

3) Normal Composition & Marshalling Order :

18 = GSLR-1 GS-3 WGACCW-1 WGACCN-3 WGSCN-6 GS-3 GSLRD-1 (58702 / 58701)

4) Rake Link : **DURG** **USL** **SDL** **APR** **BJRI** **ABKP** **Kms**

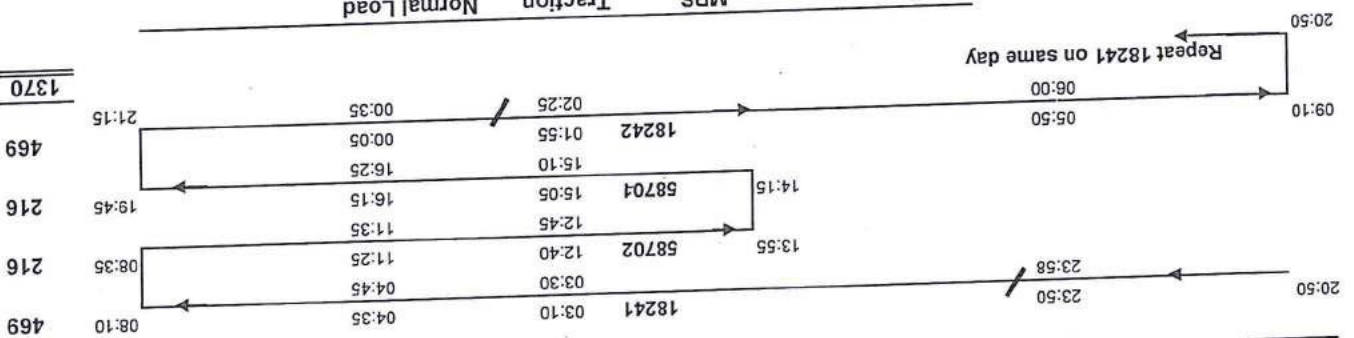

5) Load, Traction & MPS

Section	MPS	Traction	Normal Load
18241/ 58702/ 18242			58701

6) Slip Coaches :

Section	Type	Transfer	Detach from	Attach to	Contributing Rly
DURG - CHRM	WGSCN-1	BJRI	18241	58219	SEC
CHRM - DURG	WGSCN-1	BJRI	58220	18242	SEC

7) Total Rakes & Owing Rly : 2 (Two) -- S.E.C. Rly

8) Maintenance : PM --- DURG (RBPC)

9) Lie Over (in Hrs) :

Primary End : DURG 11:40
Secondary End : ABKP: 01:30

10) Traction Changing : Nil

11) Rake reversal point : 18241/18242-APR

Sub: Extension of 18242/18241(Ambikapur-Durg-Ambikapur) Express from Durg to Gondia

Extension of 18242/18241(Ambikapur-Durg-Ambikapur) Express from Durg to Gondia is not feasible due to following reasons:-

Tentative Timings on extension

Station	KMS	To Gondia	
		Existing	Proposed
18241 (Durg-Ambikapur)		Ex. Gondia	Proposed
		a.08:10	d.21:15
Ambikapur	0	a.08:10	d.21:15
Durg	269	d.20:50	09:05/09:15
Gondia	404	d.18:00	a.11:30

RJN & DGG on extended portion

- : Daily.
- : Existing composition.
- : 1 (one) Rake from Board
- : G(RBPC)
- : Electric (End-to-End)
- : **Not Feasible due to**

1. With existing lie-over, the extension is not feasible due to only 11.40 hrs lie-over at Durg and the distance between Durg-Gondia- Durg is 270 km with run time 04.45 hrs.
2. With this rake 58702/58701(Ambikapur-Shadol-Ambikapur) Passenger trains are running as commuter between Ambikapur – Bijuri in both directions. Stabling line constraint at Gondia to hold the rake with one additional rake from Board.
3. Stabling line constraint at Gondia to hold the rake with one additional rake from Board.

Stoppages
Frequency of Service
Composition
No of rakes required
Primary Maintenance
Traction
Remark

Approval of DRCC/2RUC may be obtained, if found feasible at a later date as it may cause rescheduling of Durg (Chattisgarh) by the train is extended to Gondia (Maharashtra).

28/1/16

Integrated Rake Link of 18241 / 18242 (DURG-ABKP-DURG) Express - Cum - Passenger, 58702/58701 (ABKP-SDL-ABKP) Passenger

Daily AB

- 1) Round Trip Distance : 1370 KM
- 2) End to End Distance, Run-Time & Avg. Speed
- 3) Normal Composition : 21 = GSLR-1 GS-1 WGSCN-1(DURG-CHRM Slip Coach) GSLRD-1 GS-3 WGSCN-6 WGACCN-3 WGACGW-1 GS-3 GSLR-1 (18241/18242) 18 = GSLR-1 GS-3 WGACCN-1 WGACCN-3 WGSCN-6 GS-3 GSLRD-1 (58702 / 58701)
- 4) Rake Link

SL	Train No.	Distance	Run Time	Avg. Speed	Round Trip Hours
1	18241	469	11:20	41.38	36:20
2	18242	469	11:55	39.36	
3	58702	216	05:20	40.50	
4	58701	216	05:30	39.27	

DURG USL : SDL APR BJRI ABKP Kms

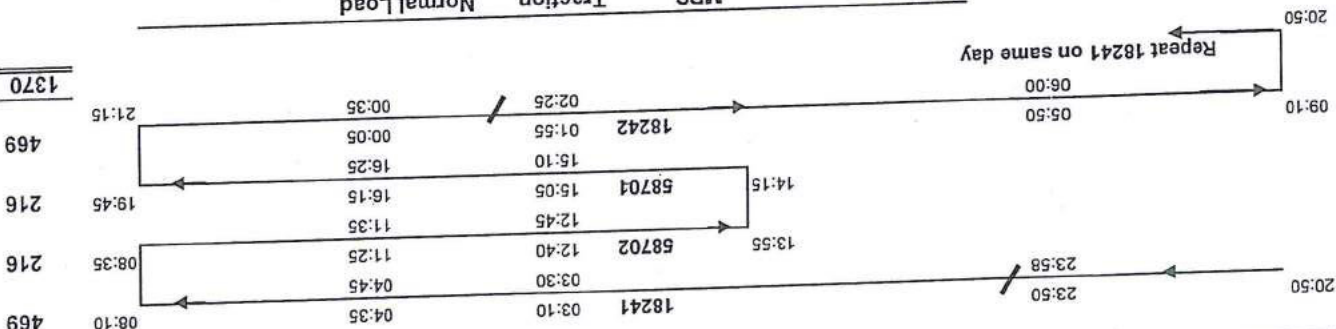

5) Load, Traction & MPS

Section	MPS	Traction	Normal Load
			18241/ 58702/ 18242 58701

6) Slip Coaches

Section	Type	Transfer	Detach from	Attach to	Contributing Rly
DURG - CHRM	WGSCN-1	BJRI	18241	58219	SEC
CHRM - DURG	WGSCN-1	BJRI	58220	18242	SEC

- 7) Total Rakes & Owning Rly
- 8) Maintenance
- 9) Lie Over (in Hrs)
- 10) Traction Changing point
- 11) Rake reversal point

2 (Two) -- S.E.C. Rly : PM --- DURG (RBPC)
 Primary End DURG 11:40
 Secondary End ABKP: 01:30
 Nil

18241/18242-APR

Item no: B(ii) SECR Agenda

Sub: Extension of 12535/12536 (Lucknow Junction- Raipur) Garib Rath Express up to

Durg

It has been decided to extend 12535/12536 (Lucknow Jn.- Raipur-Lucknow Jn.) from Raipur to Durg with change timings of 12535(Lucknow- Raipur) as given below:-

Tentative Timings

12535 (LJN-R) EXP. to DURG	KMS	Station	12536 (R-LJN) Exp. from DURG	
			Existing	Proposed
			05:05	05:05
	0	Lucknow Jn.	04:40	04:40
	4	Manaknagar	03:40	03:40
	74	Kanpur Central	23:20	23:20
	307	Ohan	20:15	20:15
	483	Katni	19:55	19:55
	486	New Katni Jn.	14:20/14:30	14:20/14:30
	804	Uslapur	12:10/12:20	12:10/12:20
	919	Raipur		
	956	Durg		

- Stoppages : Bhilai Power House on extended portion
- Frequency of Service : No change in days of Run.
- Composition : Existing composition.
- No of rakes required : No extra rake
- Primary Maintenance : Lucknow Jn (RBPC) (NER)
- Traction : Diesel (End-to-End)

No change in timing of 12535 EX LSN. due to
 Consider Betka between PKG - CFB.
 changed timing along with federal. to be extended
 but existing things CPTM 28/1/16

SECR/BSP CPTM 28/1/16
 WCR/JBP CPTM
 NCR/ALD CPTM
 NR/NDLS CPTM
 NER/GKP CPTM

28/1/16

CONFIDENTIAL

Item no: B(II) SECR Agenda

Sub: Extension of 12535/12536 (Lucknow Junction- Raipur) Garib Rath Express up to Durg

It has been decided to extend 12535/12536 (Lucknow Jn.- Raipur-Lucknow Jn.) from Raipur to Durg with change timings of 12535(Lucknow- Raipur) as given below:-

Tentative Timings

12535 (LJN-R) EXP.		Station	KMS	12536 (R-LJN) Exp.	
Existing	Proposed			Existing	Proposed
d.14:25	12.25	Lucknow Jn.	0	05:05	05:05
14:45		Manaknagar	4	04:40	04:40
16:05		Kanpur Central	74	03:40	03:40
20:40		Ohan	307	23:20	23:20
23:35		Katni	483	20:15	20:15
00.10		New Katni Jn.	486	19:55	19:55
05:15/05:25		Uslapur	804	14:20/14:30	14:20/14:30
a.07:15		Raipur	919	d. 12:20	12:10/12:20
		Durg	956	--	d.11:30

- Stopages : Bhilai Power House on extended portion
- Frequency of Service : No change in days of Run.
- Composition : Existing composition.
- No of rakes required : No extra rake
- Primary Maintenance : Lucknow Jn (RBPC) (NER)
- Traction : Diesel (End-to-End)

No change in timing of 12535 EXPR. due to
 Consider Block between MKG - CFB.
 changes timing section
 not feasible to be extended
 but country things
 CPTM 28/1/16
 CPTM 28/1/16
 WCR/JBP CPTM
 NCR/ALD CPTM
 NR/DLS
 NER/GKP CPTM
 SECR/BSP CPTM
 28/1/16

28/1/16

ASIBLE

Item no. - Railway Board's Agenda

Sub: Increase in Frequency of 18203/18204(Durg-Kanpur) Betwa Express from Bi-weekly to Tri-weekly.

Increase frequency of 18203/18204(Durg-Kanpur) Betwa Express from Bi-weekly to Tri-weekly is not feasible due to following reasons:-

Train No.	Existing frequency	Proposed frequency
18203(Durg-Kanpur)	EX DURG -Tu, Su	EX DURG -Tu, Su & Sa
18204(Kanpur-Durg)	EX CNB - We, Mo	EX CNB - We, Mo & Su

Stoppages : Same Stoppages as existing.

Frequency of Service : From Bi-weekly to tri-weekly

Composition : Existing composition.

No of rakes required : 1 rake required from Board

Primary Maintenance : Durg(RBPC)

Traction : Electric (End to End)

Remarks : There will be 126.30 hrs lie-over of rake at Durg.

Also there will be stabling constraints at

Durg. Therefore it is not feasible.

SECR/BSP
CPTM
22.11.16

WCR/JBP
CPTM

NCR/ALD
CPTM

22/1/16

Item no. - Railway Board's Agenda

Sub: Increase in Frequency of 18203/18204(Durg-Kanpur) Betwa Express from Bi-weekly to Tri-weekly.

Increase frequency of 18203/18204(Durg-Kanpur) Betwa Express from Bi-weekly to Tri-weekly is not feasible due to following reasons:-

Train No.	Existing frequency	Proposed frequency
18203(Durg-Kanpur)	Ex DURG -Tu, Su	Ex DURG -Tu, Su & Sa
18204(Kanpur-Durg)	Ex CNB - We, Mo	Ex CNB - We, Mo & Su

Stoppages : Same Stoppages as existing.

Frequency of Service : From Bi-weekly to tri-weekly

: Existing composition.

: 1 rake required from Board

: Durg(RBPC)

: Electric (End to End)

: There will be 126.30 hrs lie-over of rake

at Durg.

Also there will be stabling constraints at

Durg. Therefore it is not feasible.

Remarks

Traction

Primary Maintenance

No of rakes required

Composition

Frequency of Service

SECR/BSP
 CPTM
 2 rakes

WCR/JBP
 CPTM

NCR/ALD
 CPTM

28/1/16

Item no. H - SECR Agenda

Sub: Cancellation of 18209/18210(Dallirajhara-Raipur-Dallirajhara) Tri-weekly Express.

It has been decided to cancel the 18209/18210(Dallirajhara-Raipur-Dallirajhara) Tri-weekly Express due to poor patronization (i.e. 22%).

This train was announced in Budget 2010-11 and introduced on 27.01.2011 with composition of 10 coaches(WGSCZ-8 and SLR/SLRD-2). Due to poor patronization, the composition was reduced to 8 coaches(WGSCZ-6 and SLR/SLRD-2) from 16.09.15.

DRM/Raipur has suggested cancellation/withdrawal of this service with consent of Members of DRUCC and same has been agreed upon unanimously by the Members of ZRUCC during the ZRUCC meeting on 29-12-2015 which was chaired by GM.

All the papers required for the purpose have been submitted to Railway Board.

28/01/16
CPTM
SECR/BSP

Confidential

Minutes of IRTTC Meeting held at Chennai

From 27th to 29th January-2016

Item no: A(i) SECR Agenda

Sub: Bilaspur-Madgaon (Weekly) Super Fast Express.

It has been decided to introduce a new train between Bilaspur-Madgaon-Bilaspur as per the details given below:-

Tentative Timings

Arr.	Dep.	Kms	Stations	Arr.	Dep.
06:50	--	0	Bilaspur	11:45	--
18:45	23:55 (Su)	411	Nagpur	00:25	11:25
23:25	07:00	1308	Roha	19:20	19:15
07:40 (Tu)	19:00	--	Igatpuri	11:00 (Tu)	00:10
31:45	23:30	1750	Madgaon	31:40	19:20
55.26	31:45		Time of run	55.26	31:40
	55.26		Avg. Speed		55.26

Stoppages	Frequency of Service	Composition	No of rakes required	Primary Maintenance	Traction	Remark
SECR: R, DURG, RJN, G, BRD CR : NGP,WR,PLO,DMN, BD, AK,SEG, BSL, MMR, NKRD, KYN, PNVL, ROHA KRCL: KHED, CHI, RN, SND, SWV, KRMI	Weekly (Ex. BSP- Sun and Ex. MAO-Tue)	SLR-2, GS-6, GSCN-8, ACCN-3, ACCW-2, WCB-1, = 22 Coaches	One rake from Railway Board	Bilaspur (RBPC)	Electric (BSP-IGP), Diesel (IGP-MAO)	In up direction from BSP to NGP via Itwari and In Down direction from NGP to BSP via Kalumana direct.

28/1/16

SECR/BSP

CPTM

CR/Mumbai

CPTM

KRCL/Mumbai

/COM

CR Remarks - Timings not feasible
due to NGP- WR & BSL length
of track & section capacity to allow

28/1/16

Item no. - Railway Board's Agenda

Sub: Increase in Frequency of 12823/12824 (Durg-Nizamudin-Durg) C.G. Sampark Kranti Express from tri-weekly to daily.

It has been decided to increase frequency of 12823/12824 (Durg- Nizamudin-Durg) C.G. Sampark Kranti Express from tri-weekly to daily.

Train No.	Existing frequency	Proposed frequency
12823 (Durg-Nizamudin)	Ex DURG-Mo, Th & Sa	Daily
12824 (Nizamudin-Durg)	Ex NZM-Tu, Fr & Su	Daily

Stoppages : Same Stoppages as existing.

Frequency of Service : From tri-weekly to Daily

Composition : Existing composition.

No of rakes required : 2 rakes required

Primary Maintenance : Durg(RBPC)

Traction : Electric (End to End)

Remarks

: 12549(Durg-Jammu Tawi) weekly running on Tuesday on the path of 12823 is proposed to run on the path of 18215 (Durg-Jammu Tawi) weekly.

It is proposed that Chhattisgarh Sampark Kranti Express will run for additional three days using the path of Madhya Pradesh Sampark Kranti Express.

SECR/BSP

CPTM

28/01/16

WCR/JBP

CPTM

NCR/ALD

CPTM

NCR is having four coaches.

NR/NDLS

CPTM

Not feasible due to full occupancy of all seven days. No additional stop available at Huzurabad. Will change number of train at 1400 hrs.

(A) Timing of 12122 Hzm-JBP (Krant) will be Reversed to leave Hzm at 17.05 and arrive at 17.25. (B) 12824 will leave Hzm at 17.25 (Current Timing)

28/1/16
for class/HR

29/1/16
for class/HR

MINUTES OF IRTTC - 2016 AT CHENNAI
FROM 27.01.2016 TO 29.01.2016

Supplementary Proposal Item No. 2 of South Western Railway
(Ref. : CPTM/SWR's Letter No. T. 454/IRTT/C/Vol. I/2016-17 dated 14.01.2016)

2(a). Running of Trains via YPR bye pass to avoid engine reversal/ traction change.

It is proposed to run the following Trains directly via YPR bye pass line by providing stoppage at BAW, HBB and BAND without touching YPR so as to avoid traction change/reversal and congestion at YPR resulting to saving of 30 minutes running time. Traction change can be done at convenient stations. (at BAW or KTM or BWT)

Sl No.	Train No.	Present Route	Proposed Route
1	17312/17311 VSG-MAS- VSG Weekly	BAW, YPR, BAND	BAW, BAND
2	17314/17313 UBL-MAS- UBL Weekly	BAW, YPR, BAND	BAW, BAND
3	12777/12778 UBL-KCVL- UBL Weekly	BAW, YPR, BAND	BAW, BAND
4	17315/17316 VSG-VLNK- VSG Weekly	BAW, YPR, BAND	BAW, BAND
5	11005/11006 DR-PDY-DR Tri Weekly	BAW, YPR, BAND	BAW, BAND
6	11021/11022 DR-TEN-DR Tri Weekly	BAW, YPR, BAND	BAW, BAND

Discussed and agreed

CPTM/SWR/UBL

/Railway Board

29/1/16

MINUTES OF IRTTC - 2016 AT CHENNAI
FROM 27.01.2016 TO 29.01.2016

South Western Railway Proposal

Proposal for running of Bi-weekly Suvridha Special Express between Yesvantpur and Kochuveili

Abstract Timings :

Days of Service	YPR - KCVL Special Express	A/D	Station	A/D	KCVL - YPR Special Express	Days of Service
Wed, Sat	21.00	D	Yesvantpur	A	09.30	Fri, Mon
Thu, Sun	12.40	A	Kochuveili	D	17.00	Thu, Sun

Dates of Service : Advised on demand.

Composition : Scratch rake of 21 coaches will be formed.

Maintenance : YPR with RBPC

Stoppages : BAND, HSRA, DPJ, SA, ED, CBE, PGT, TCR, AWY, ERN, KTYM, CHY, CNGR, MWLK, KYJ, QLN [Existing stoppages of T. No. 12257/12258 (YPR - KCVL - YPR) Garib Rath Express]

Discussed and Agreed

SRI/MAS Remarks : KCVL - YPR Suvridha Special cannot be run on days when TVC - BNC Premium Suvridha Specials are running as same Ex. KCVL and path clashing from Erode.

[Signature]
CPTM/SWR/CBL

[Signature]
29.1.16
CPTM/SR/MAS

[Signature]
29/1/16
/Railway Board

SUVRIDHA EXPRESS

MINUTES OF IRTTC - 2016 AT CHENNAI
FROM 27.01.2016 TO 29.01.2016

Supplementary Proposal Item No. 2 of South Western Railway
(Ref.: CPTM/SWR's Letter No. T. 454/IRTT/C/Vol. I/2016-17 dated 14.01.2016)

2(b). Diversion of Train No. 12691/12692 (MAS - SSPN - MAS) Weekly Express via
KJM, CSDR, YNK

Diversion of Train No. 12691/12692 (MAS - SSPN - MAS) Weekly Express via KJM,
CSDR, YNK without touching SBC to avoid engine reversal at SBC duly providing stoppage at
YNK, CSDR, WFD resulting to saving of 60 minutes running time.

Sl No.	Train No.	Present Route	Proposed Route
1	12691/12692 MAS-SSPN- MAS Weekly	KJM, SBC, YNK	KJM, CSDR, YNK, WFD

[Discussed and agreed]

[Signature]
29/1/16
CPTM/SWR/UBL

[Signature]
29/1/16
/Railway Board