



SSS
400+



VI-STR



WBL

Schunk – Your Partner for Innovative Railway Engineering

IRIS
Certification



Schunk Bahn- und Industrietechnik GmbH



Innovation for High Speed Applications

400 km/h and more

*Schunk - special collector strips
for the highest speeds*

*Air wings for fine tuning
aerodynamic properties*

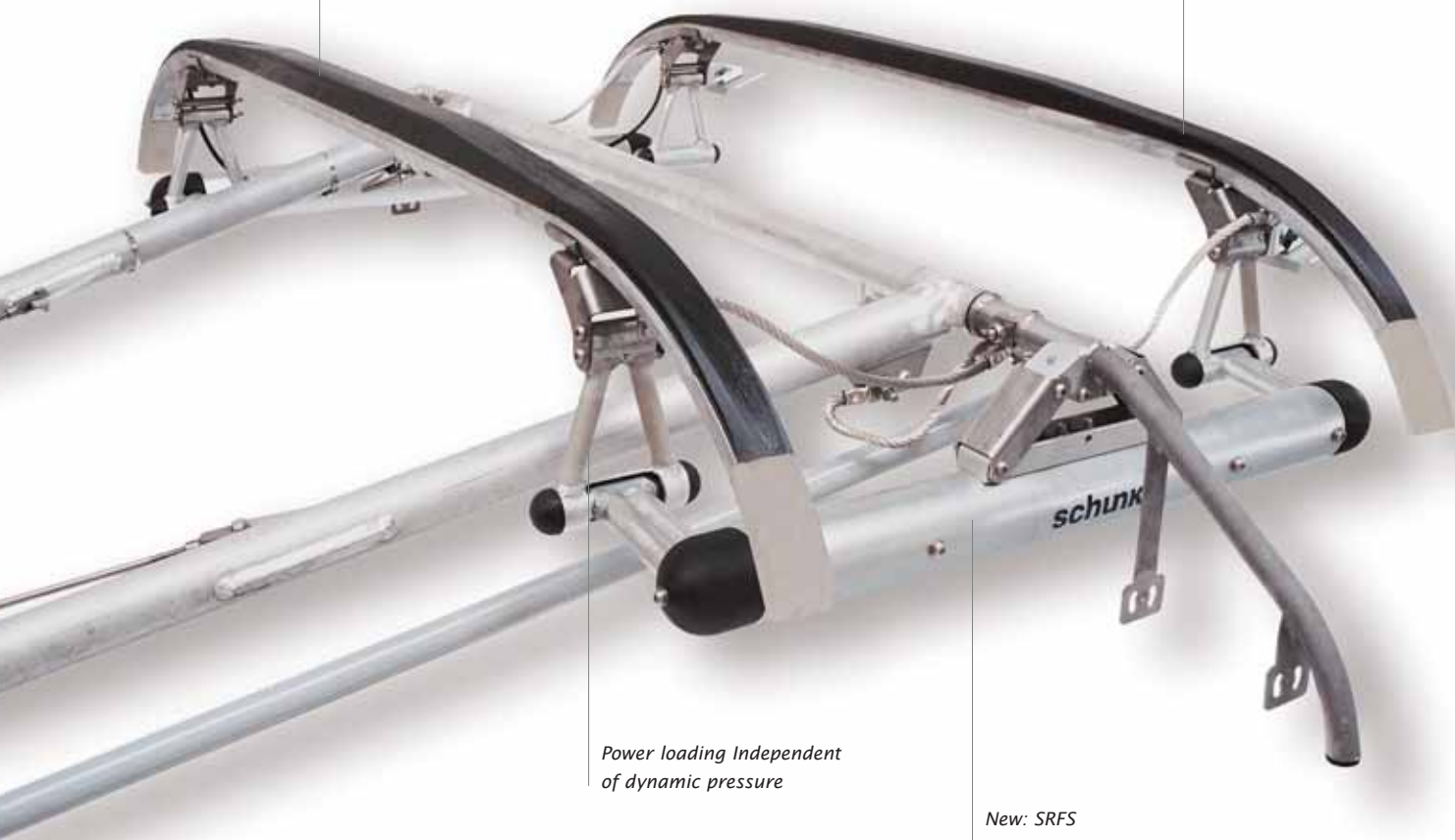

*Power loading Independent
of dynamic pressure*

*New: SRFS
Schunk - Rotational Spring
Suspension System significantly
reduces dynamic pressure*

The new high speed rotational spring pan head

With the development of a new high speed rotational spring pan head, Schunk has demonstrated its dedication to finding modern innovative solutions. The challenges which needed to be overcome in order to achieve the desired results were formidable. Six development goals were the focus of our attention:

- Optimization of the dynamic behavior
- Elimination of the effects of the dynamic pressure on the pan head suspension
- Reduction of the dynamic pressure force effect on the pantograph
- Minimization of aerodynamic impacts on the distribution of contact pressure
- Low level of noise emission
- Adaptability of the pan head to various operating conditions

The results are impressive:

Lower dynamic pressure-optimized distribution of contact pressure

By separating the direction of the dynamic pressure and the spring direction, the impact of the dynamic pressure on the pan head suspension is eliminated.

With a semi trailing link suspension an imaginary pan head bearing point is created. Thus a rotation of the pan head is avoided. The same contact pressure is applied to both collector strips.

Reduction of air resistance, light weight design, improved aeroacoustics

Minimized surface and a lower air drag coefficient result in a lower dynamic pressure. That minimizes the forces on the pantograph frame at high speeds. The pan head shaft is made of extremely strong aluminum alloy with a special hard coating. The use of closed components and aeroacoustically optimized contours significantly reduces noise emissions.

Optimal adaptability

The use of various carbon strip distances, pan head widths and spring constants with the SSS 400+ allows for optimal adaptation to different clearance gauges and overhead wire systems. This innovative pan head can also be adapted to various other pantograph types.

■ Schunk – Innovation as a driving force

Many path-breaking technical innovations can be attributed to Schunk engineers.

■ Constantly exploring for our customers

Novelties in the field of Railway engineering such as carbon run-off horns, individual suspension, bellow drive mechanisms or rotational pan heads are examples for Schunk's constant search for better solutions for the benefit of the customer.

The SSS 400+ another example for Schunk's performance in innovation.



*Pantograph,
the result of successful
development teamwork*

- Various carbon strip distances
- Various pan head widths
- Various spring constants

Pantographs with clear advantages

The innovative WBL series

The pantographs of the innovative WBL Series were designed for normal speeds through the highest speeds. Reduction in mass and optimal aerodynamic adaptation, guarantee the best possible performance. Individually suspended collector strips provide good contact behavior. In addition, the pantograph is pneumatically damped. As options, Schunk offers an automatic lowering device, frame parts made of light weight components or stainless steel as well as pneumatic control for the regulation of contact pressure.

The compact SBE Series

The pantographs of the SBE line are single arm pantographs with spring raising mechanisms and insulated electrical lowering devices. The advantages are: compact dimensions coupled with maximum range.

■ WBL Series

Innovative solutions for normal speeds up to the highest speeds

■ SBE Series

Robust pantographs for light rail and tram vehicles

■ SBF Series

Proven design, even when used under difficult conditions

For technical details please call telephone number on the back on this prospect

These pantographs are well suited for subway and tram vehicles. As options you may choose from: individually suspended collector strips with even better contact behavior, hydraulic damping, a lock down latch in the resting position and an automatic lowering device.

The robust SBF Series

The pantographs of the SBF Series are based on the SBE pantographs. All the essential components from the SBE Series have been adopted except for the electrical lowering device. For using this pantograph, a simple low volume pressurized air supply is sufficient. Among the advantages are: simple maintenance and a pneumatic spring lowering device. As options we offer: individually suspended collector strips, hydraulic damping of the frame, an automatic lowering system as well as electric/pneumatic resting position indication.



Hydraulic frame damping

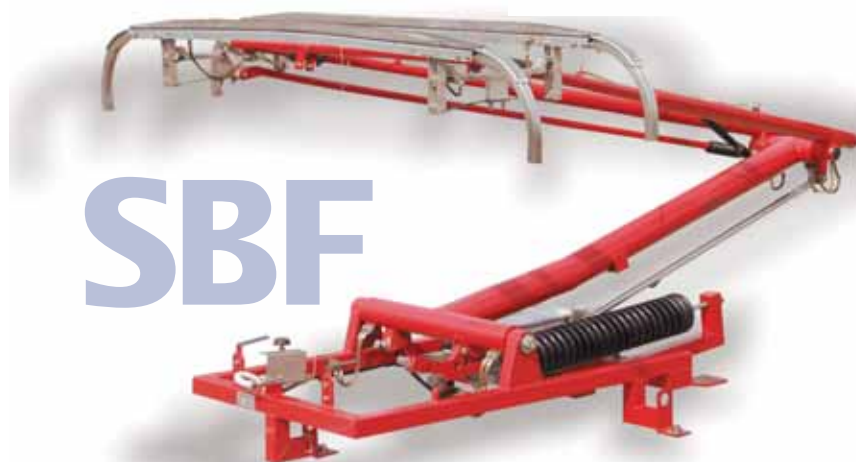

SBF

Robust pantographs, specially made for light rail vehicles. Proven under difficult operating conditions.

Upper arm with the highest degree of vertical stability (steel or aluminum models)



Maintenance free bearings

Integrated air bellow drive system



Independent individual suspension

WBL



SBE

*Single arm pantograph.
Compact dimensions coupled
with maximum range*

Fully insulated 3rd rail pantograph with a bright future

The new Schunk VI-STR fully insulated pantograph

The Schunk VI-STR 3rd rail pantograph is a completely new development with decisive advantages for the operator.

- On the Schunk VI-STR pantograph the mounting plate to the bogie is completely insulated
- The Schunk VI-STR pantograph runs with maintenance free bearings and maintenance free pneumatic cylinders

With such features, the Schunk VI-STR significantly reduces operating costs.

Operating safety and maintenance free prevail

The new Schunk 3rd rail pantographs are already being successfully used at many transit companies.

More and more customers are choosing the superior technology of the Schunk pantograph.

This includes the special insulation, a material-friendly break point system as well as low maintenance overall design.

VI-STR De

Entire system successfully tested for shock, insulation, environment conditions and vibrations, in accordance with DIN and EN standards



Proven standard-collector strips made of cast iron for steel conductor rail



Copper collector strips for steel conductor rails



Multi-component carbon strip, casted design, good sliding properties



Full carbon collector strip. Especially suited for aluminum conductor rails, with high-grade steel inlay



Mechanically strong metal impregnated collector strips for the transfer of high currents

R etails

*Mounting of a lever for manual raising and lowering
Pressurized air unit completed with shock struts*

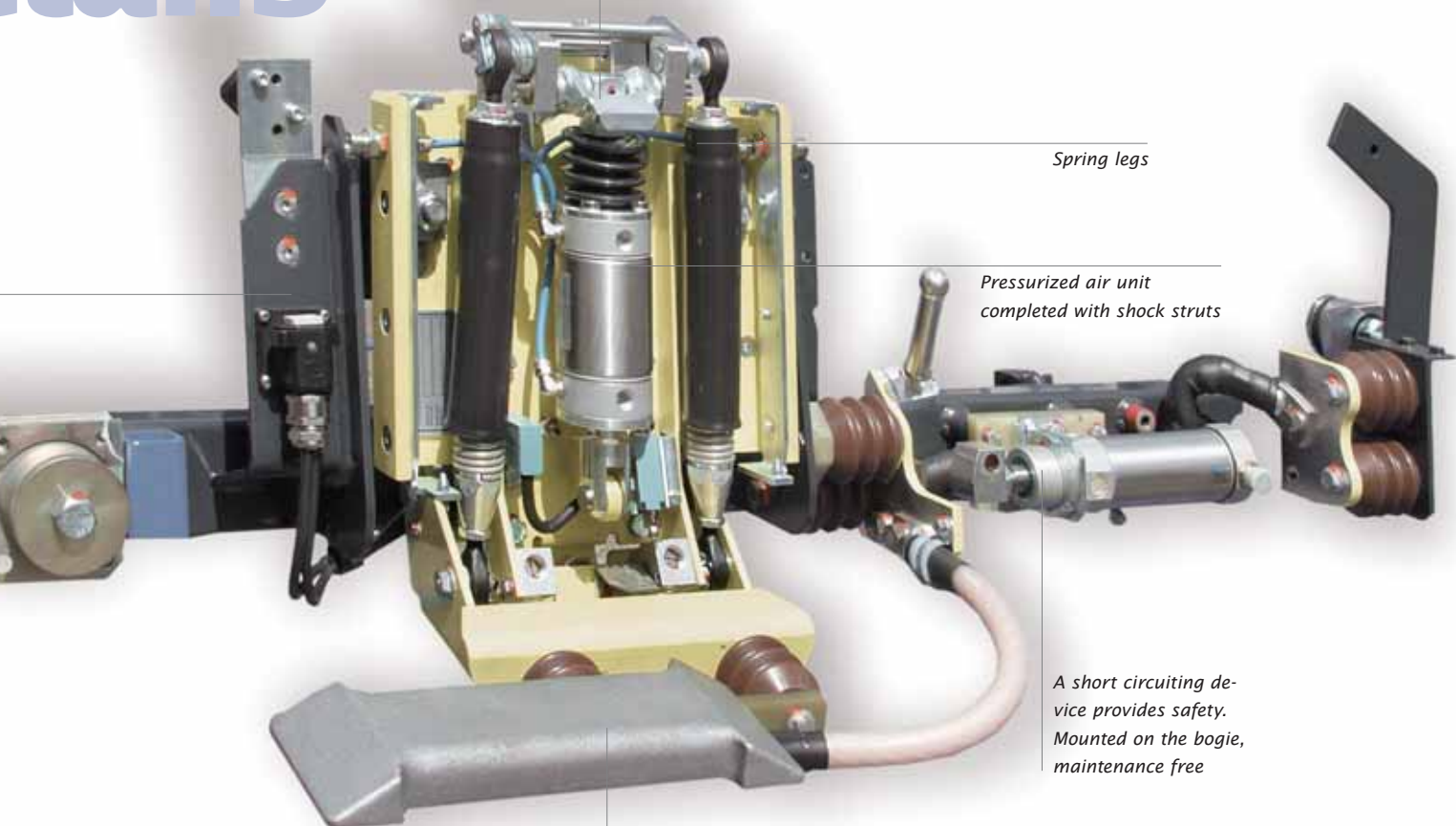

Spring legs

Pressurized air unit completed with shock struts

*A short circuiting device provides safety.
Mounted on the bogie,
maintenance free*

Collector strips for horizontal and vertical conductor rails



*3rd rail pantograph
with GFRP protection
cover and lever*

Germany

- Schunk Kohlenstofftechnik GmbH
Germany/Heuchelheim
Telephone: +49 (641) 60 80
E-Mail: infobox@schunk-group.com
- Schunk Bahn- und Industrietechnik GmbH
Germany/Wettenberg
Telephone: +49 (641) 80 30
E-Mail: sales.sbi@schunk-group.com
- Schunk Kohlenstofftechnik
Dresden GmbH
Germany/Dresden
Telephone: +49 (351) 2 70 90 07
E-Mail: viola.puls@schunk-group.com

Europe

- Schunk Nordiska AB
Sweden/Lenhovda
Telephone: +46 (474) 2 95 00
E-Mail: info@schunk.se
- Schunk UK Ltd.
Great Britain/Pudsey
Telephone: +44 (113) 2 56 72 38
E-Mail: schunk.uk.sales@schunk-group.com
- Schunk Benelux B.V.
Netherlands/Rotterdam
Telephone: +31 (010) 4 14 47 66
E-Mail: info@schunk-rotterdam.nl
- Schunk Electrographite SAS
France/Nanterre Cedex
Telephone: +33 (141) 19 52 52
E-Mail: schunk.france@schunk-group.com
- Schunk Iberica S.A.
Spain/Pinto
Telephone: +34 (91) 6 91 25 11
E-Mail: mail@schunk.es

- Schunk Portugal Lda
Portugal/Marinha Grande
Telephone: +351 (244) 57 24 80
E-Mail: sede@schunk.pt
- Schunk AG
Switzerland/Adliswil
Telephone: +41 (44) 7 16 46 46
E-Mail: info@schunk.ch
- Schunk Wien Gesellschaft m. b. H.
Austria/Vienna
Telephone: +43 (1) 61 66 80 70
E-Mail: swa.office@schunk-group.com
- Schunk Bahn- und Industrietechnik GmbH
Austria/Bergheim
Telephone: +43 (662) 45 92 00
E-Mail: office@schunk-group.at
- Hoffmann & Co. Elektrokohle AG
Austria/Bad Goisern
Telephone: +43 (6135) 40 00
E-Mail: office@hoffmann.at
- Schunk Italia S.r.l.
Italy/Magenta
Telephone: +39 (02) 9 72 19 01
E-Mail: info@schunkitalia.it
- Schunk Bahntechnik Polska Sp. z. o. o.
Poland/Warszawa
Telephone: +48 (22) 8 24 04 11
E-Mail: biuro@wktp.pl
- Schunk Praha s. r. o.
Czech Republic/Plzen
Telephone: +420 (377) 45 41 11
E-Mail: milan.kroc@schunk-group.com
- Schunk Carbon Technology SRL
Romania/Bukarest
Telephone: +40 (21) 3 37 28 59
E-Mail: office@schunk.ro
- SIRMA Elektrik Kömürleri SAN TIC AS
Turkey/Istanbul
Telephone: +90 (212) 2 78 99 70
E-Mail: info@schunkturkey.com

America

- Schunk Graphite Technology LLC
USA/Menomonee Falls
Telephone: +1 (262) 2 53 87 20
E-Mail: info@schunkgraphite.com
- Schunk Electro Carbón, S.A. de C.V.
Mexico/Ocoyoacac
Telephone: +52 (728) 2 82 78 90
E-Mail: informacion@schunk.com.mx
- Schunk do Brasil Ltda.
Brasil/São Paulo
Telephone: +55 (11) 46 13 32 00
E-Mail: schunk@schunk.com.br

Australia

- Unique Engineering Australia Pty. Ltd.
Australia/Fountain Gate
Telephone: +61 (3) 97 05 95 22
E-Mail: sales@uniqueengineering.net.au

Asia

- Schunk General Carbon (Guangzhou)
Co., Ltd.
China/Guangzhou
Telephone: +86 (20) 34 63 48 88
E-Mail: scc@schunkchina.com
- Schunk General Carbon Ltd.
China/Hong Kong
Telephone: +852 (2) 4 08 66 88
E-Mail: sqc@schunkhk.com
- Seung Lim Carbon Metal Co., Ltd.
South-Korea/Ansan-City
Telephone: +82 (31) 4 91 27 22
E-Mail: shcho@seunglim.co.kr
- Pichit Industrial Works Co. Ltd.
Thailand/Bangkok
Telephone: +66 (56) 63 34 27
E-Mail: info@pic.co.th
- Schunk Metal & Carbon (I) PVT. Ltd.
India/Bangalore
Telephone: +91 (80) 8 51 67 08
E-Mail: schunk@vsnl.com

Schunk Bahn- und Industrietechnik GmbH

Hauptstrasse 97
35435 Wettenberg
Germany

Telephone: +49 (641) 803-0
Telefax: +49 (641) 803-139

www.schunk-sbiw.com

Aupoint 23
5101 Bergheim (Salzburg)
Austria

Telephone: +43 (662) 459200
Telefax: +43 (662) 459200-1

www.schunk-sbis.com